

Level Control & Pressure Sustaining Valve with Modulating Vertical Float

(Sizes 1.5"-14"; DN40-350)

Description

The Model 753-67 Level Control & Pressure Sustaining Valve with Modulating Vertical Float is a hydraulically operated, diaphragm actuated valve that controls reservoir filling to maintain constant water level, regardless of fluctuating demand. During filling, it sustains minimum upstream pressure.

Installation

1. Ensure enough space around the valve assembly for future maintenance and adjustments.
2. Prior to valve installation, flush the pipeline to insure flow of clean fluid through the valve.
3. For future maintenance, install Isolation gate valves upstream and downstream from Bermad control valve.
4. Install the valve in the pipeline with the valve flow direction arrow in the actual flow direction. Use the lifting ring provided on the main valve cover for installing the valve
5. For best performance, it is recommended to install the valve horizontally and upright. For different valve positions – consult Bermad.
6. It is highly recommended to install a strainer Bermad model 70F upstream from the pressure reducing valve, to prevent debris from damaging valve operation.
7. After installation carefully inspect control tubing & fittings for damage and loose connections.
8. Install a pressure gauge (instead of the plastic plug).
9. Install the float pilot assembly either at an external balancing tank or at an internal stilling tank (refer to the enclosed "Float #67" catalog page).
10. Pull a 1/2" or 3/8" control tube, from the valve to the float.
11. Determine the desired rod length according to level differential between the float assembly and reservoir desired level.
12. Assemble the extension rods to the upper rod and to one another. Apply glue ("Loctite 200" or equivalent) and screw tight. Be careful not to damage the rod.
13. Install the upper & lower stoppers on the rod without the float ball. Use 3/16" Allen-Key to lock the stoppers on the rod.
14. Screw the upper rod to its place at the bottom of the lever system & tighten the lock nut by 1/2" spanner.
15. Balance the float assembly by moving the weight against the rod and stoppers (without the float ball). After reaching equilibrium, tighten the balancing-weight screw and its lock-nut by 7/16" spanner.
16. Remove the lower stopper to enable threading-in the float ball. Reassemble the lower stopper & lock it in its place.
Note: You may have to pull out the whole rod, in order to reach the lower stopper. If so, release the rod lock-nut, unscrew the installed rod (with its extensions & the stoppers) and pull it up from the stilling tank. After threading-in the float ball and locking the lower stopper back in its place, reassemble the installed rod.
17. Connect the control tube ends, using 3/8" copper or reinforced plastic tube, to the valve and to the float, according to control drawing below, from cock valve [2] to float inlet (upper) port.

Commissioning & Calibration

1. Confirm that cock valves [1], [2] & [3] are open (handle parallel to cock-valve body).
2. Confirm that the supply pressure is typical.
3. Adjust the water level by setting the stoppers:
 - 3.1. Hold the lever system at its upper position & set the upper stopper to 100 mm below desired upper level (but not higher than 150 mm below over-flow level).
 - 3.2. Slide the float ball up towards the upper stopper and anchor it by the lower stopper.
4. Open upstream and downstream isolating valves. Allow the 753-67 to open (ensuring the lever system is at its lower position) and fill-up the reservoir, while performing the below specified procedure:
 - 4.1. Calibrating the Pressure Sustaining Pilot & Venting air from the valve control loop:

The Model 753-67 is factory set to the system minimum allowed pressure. The set pressure is marked on the pilot's label. If the set pressure is either different from the design or the requirements have been changed, follow the below steps:

 - 4.1.1. Close the upstream isolating valve to reduce 753-67 inlet pressure. Ensure that the 753-67 sustains the upstream pressure, preventing it from decreasing below setting, even when the upstream isolating valve is almost closed.
 - 4.1.2. Unlock the pilot locking nut and slowly turn the pilot adjusting screw Clock-Wise to increase set pressure and Counter-Clock-Wise to decrease it.
 - 4.1.3. After the pressure is stabilized, lock the pilot locking nut and open fully the upstream isolating valve.
 - 4.1.4. During filling the reservoir move the lever-system manually to its upper position, forcing the valve to close, then to its lower position, forcing the valve to open. At each position, vent air from the valve control loop by loosening tube fitting at the highest point (float ports and at valve & pilot covers), allowing the air to bleed. Retighten the fittings eyebolts.
 - 4.2. Calibrating reservoir level:

Ensure that the 753-67 closes as the water level reaches the set-level. If the 753-67 has not closed, move the lever-system manually to its upper position, forcing the valve to close. Change the stoppers location down, to lower level setting or up to raise it, until the valve closes automatically at the desired upper-level. Allow the water level to drop by consuming from the reservoir or by draining it. This will cause the valve to open.
5. The Restriction [31] enables the 2-Way control & reduces valve closing speed.
6. Cock valve [2] enables manual closing.

Control Drawing

PARTS LIST

1	2W Cock Valve
2	2W Cock Valve
3	2W Cock Valve
4	Control Filter
31	Restriction Orifice
#3PB-R	2W PB PS Pilot R Sensing
67	2W Modulating Vertical Float

--- Connected by Customer

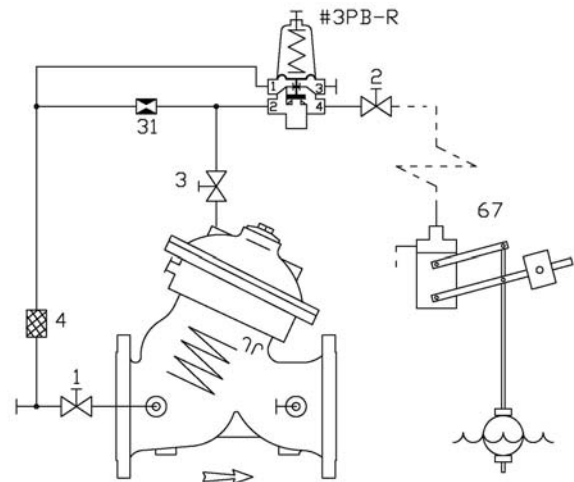

Trouble-Shooting

- Valve fails to Open:** Check for sufficient inlet pressure, create demand/flow, confirm pilot & float setting & check cock valves status.
- Valve fails to Close:** Create demand/flow, confirm pilot & float setting, check cock valves status, clean control filter & detect for clogged ports or fittings, check if any debris trapped in the main valve, confirm diaphragm is not leaking.
- Valve fails to Regulate:** Check cock valves status, release air trapped in the 753-67 control chamber & the pilot's ports.

Preventative Maintenance

- System operating conditions that effect on the valve should be checked periodically to determent the required preventative maintenance schedule.
- Maintenance instructions:
 - Tools required:
 - Metric and imperial wrenches
 - Anti seize grease
 - Visual inspection to locate leaks and external damages
 - Functional inspection including: closing, opening and regulation.
 - Close upstream and downstream isolating valves (and external operating pressure when used).
 - Once the valve is fully isolated vent pressure by loosening a plug or a fitting.
 - Open the stud nuts and remove the actuator as one unit from the valve body. Disassemble necessary control tubs.
 - It is highly recommended to stock a reserve actuator assembly for each size. This allows minimum system field work and system down time.
 - Disassemble the actuator and examine its parts carefully for signs of wear, corrosion, or any other abnormal conditions.
 - Replace worn parts and all the Elastomers. Lubricate the bolts and studs threads with Anti seize grease.

Spare parts

Bermad has a convenient and easy to use ordering guide for valve spare-parts and control system components. For solenoid valves refer to model and S/N on solenoid tags.

Pub #: IOMEW753-67	By: MB 7/11	Rev:	File name: IOMEW753-67_07_11
--------------------	-------------	------	------------------------------



appliceng@bermad.com • www.bermad.com

The information contained in this document is subject to change without notice.

BERMAD shall not be liable for any errors contained herein. All Rights Reserved. © Copyright by BERMAD Control Valves.