

## Bermad 400E-6DC

### Electro Pneumatically Pressure Control On Off Deluge Valve

**Installation**

**Operation**

**Maintenance**



**UL LISTED**

Application Engineering

**Bermad**

## 1. Safety First

BERMAD believes that the safety of personnel working with and around our equipment is the most important consideration. Please read all safety information below and from any other relevant source before attempting to perform any maintenance function.

Comply with all approved and established precautions for working with your type of equipment and/or environment.

Authorized personnel should perform all maintenance tasks.

Prior to performing a procedure, read it through to the end and understand it. If anything is not clear, ask the appropriate authority.

When performing a procedure, follow the steps in succession without omission.

## 2. Description

The BERMAD Model 400E-6DC pressure controlled Deluge valve is suitable for systems that include pneumatic release system and a piping system with a wide variety of open nozzles. Combining a pressure control feature, the model 400E-6DC is recommended for a system that requires pressure control.

The BERMAD Model 400E-6DC requires a pneumatic release system, equipped with thermostatic releases, a listed System Control Panel with a compatible electric detection system and/or fixed temperature releases and pneumatic pressure supply system.

The specific trim for the electro pneumatic pressure controlled Deluge Valve Type 6DC includes a includes a electric solenoid valve (24B fig.1), PORV Pneumatic Actuator (6B fig.1), normally held closed by pressure maintained in the pneumatic release system, a #2-UL Pressure Reducing Pilot Valve (2R fig.1) and a Manual Emergency Release (15B fig.1).

In fire conditions, the release device on the control trim releases the pressure from the upper chamber, allowing the Deluge Valve (1 fig.1) to modulate open allowing water to flow into the system at the preset pressure. Water flows from any open nozzles and to alarm devices. The Deluge Valve with Pressure Reducing Trim is recommended where it is necessary to guard against over-pressure while maintaining a preset discharge pressure during system operation. This feature allows regulation of total system demand and can be used to limit excess flow from deluge systems with high-pressure water supply, or to reduce outlet pressure to a constant value according to the system component pressure rating and design, regardless of changes in the deluge valve inlet pressure.

This feature is also recommended where a reduction of pressure surges and/or water hammer is desired.

Deluge Systems are commonly used where it is desirable to simultaneously spray water from all open sprinklers and/or nozzles while the system is operating.

In the SET position, the line pressure supplied to the main valve's control chamber via the priming line, and through a Check Valve, an Accelerator with a priming restriction is trapped by the Check Valve, by the closed PORV and by a closed Manual Emergency Release. The trapped pressure holds the main valve's diaphragm and plug against the valve seat, sealing it drip tight and keeping the system piping dry.

Under FIRE condition, pneumatic pressure is lost causing the PORV valve to open. Pressure is then released from the main valve's control chamber to the downstream, through the Pressure Reducing (PR) Pilot and the open PORV. Should system pressure rise above PR pilot setting, the PR pilot throttles, thereby enabling pressure to accumulate in the valve control chamber. This causes the 400E-6DC to throttle closed, decreasing system pressure to PR pilot setting. The Manual Emergency Release (15B fig.1) overrides the PORV pilot, causing the 400E-6DC to open.

**Flow and Pressure for Models 400E-2MC 2C, 3C, 3DC, 4C, 4DC, 5C, 5DC, 6C & 6DC**

Valves sizes	2"	2½"	3"	4"	6"	8"	10"
<b>Rated Inlet Pressure</b>	250	250	250	250	250	250	250
<b>Outlet Pressure Adjusting Range [psi (barg)]</b>	30-165 (2-11.5)	30-165 (2-11.5)	30-165 (2-11.5)	30-165 (2-11.5)	30-165 (2-11.5)	30-165 (2-11.5)	30-165 (2-11.5)
<b>Minimum Flow-Rate [GPM (m3/hr)]</b>	44 (10)	50 (11.5)	110 (25)	180 (401)	400 (91)	450 (102)	660 (150)
<b>Maximum Flow-Rate [GPM (m3/hr)]</b>	150 (34)	270 (61)	450 (102)	700 (159)	1600 (363)	3500 (795)	5000 (1136)

➔ **Note:** The pressure reducing capabilities of these deluge valves have been evaluated by UL within the pressure and flow characteristics as described herein.

**Attainable outlet pressure at inlet under-pressure**

The following chart indicates the attainable outlet pressure available when the inlet pressure falls below the intended outlet pressure setting.

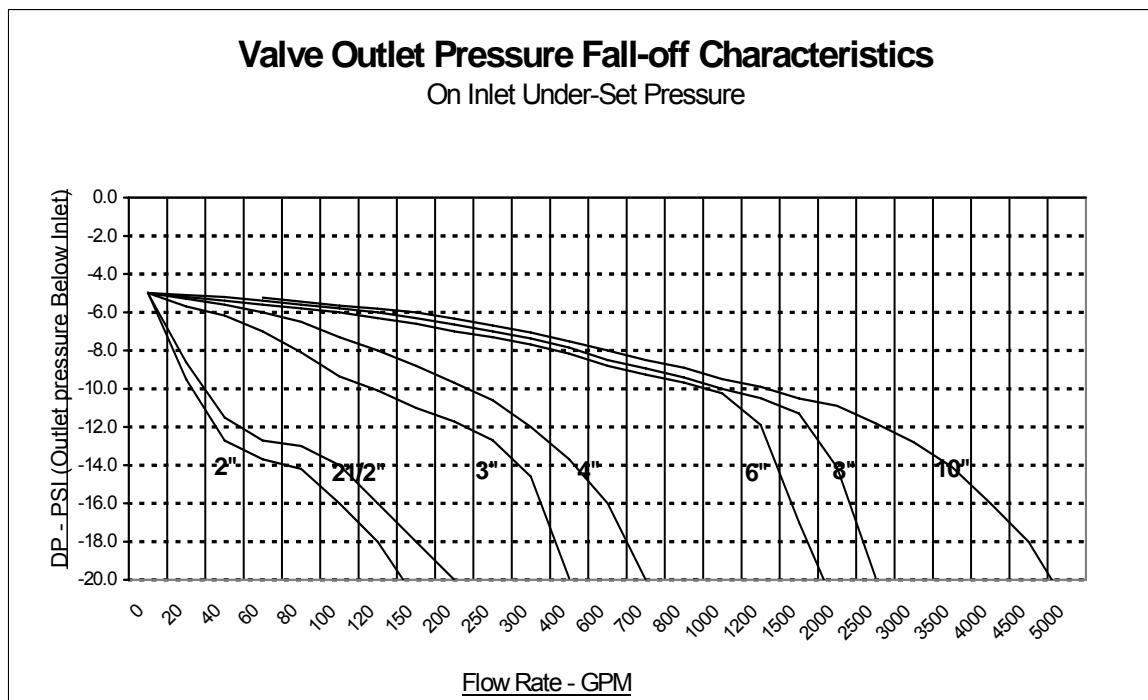

### 3. UL Listed

BERMAD 400E-6DC Deluge Valve is UL Listed when installed with specific components & accessories. Refer to the current UL Directory. Consult the manufacturer for any component approval recently to appear in the UL fire protection equipment directory.

### 4. Installation

Subject to all other instructions, drawings and technical specifications, which describe the BERMAD 400E-6DC Deluge Valve, install in their proper positions the components comprising the Deluge Trim Package, according to the drawing relevant to the specific type, hereby enclosed.

- 4.1. Allow enough room around the valve assembly for any adjustments and future maintenance/disassembly work.
- 4.2. Before the valve is installed, flush the pipeline to remove any dirt, scale, debris, etc. Failure to do this might result in the valve being inoperable.
- 4.3. Install the valve in the pipeline with the valve flow arrow on the body casting in the proper direction. Ensure that the valve is positioned so that the cover/actuator can be easily removed for future maintenance.
- 4.4. Ensure that all other components are positioned correctly as per the appropriate drawing.
- 4.5. The water supply priming line must be connected to the upstream of the system control valve.
- 4.6. Subject to all other instructions, drawings and technical specifications, which describe Bermad Deluge Valve, install in their proper positions the components comprising the Deluge Trim Package, according to the drawing relevant to the specific type, hereby enclosed.
- 4.7. Install also the additional accessories, which appear in the drawing and which must be installed as shown in the schematic drawing.
- 4.8. Install a pneumatic pressure supply system; see "Pneumatic System Pressure Requirements" below.
- 4.9. Pneumatic System Pressure Requirements:

A regulated supply of pressurized air or nitrogen is required to maintain a pneumatic pressure supply system, See "Placing in Service" section below prior to connecting the air supply to the system.

The Pneumatic system shall use a clean, dependable and continuous (24 hours a day, 7 days a week) compressed-air source using an independent air compressor or an Air Maintenance Device supplied by a dry nitrogen-gas supply or external high Air pressure source.

NOTE: Any event of an air supply failure, slow leakage of air from the pneumatic system, will result in activation of the PORV, causing the Deluge Valve to open. Water will then flow from any open sprinklers and/or spray nozzles on the system and the Alarm will operate.

- 4.10. Electrical & Solenoid Requirements: The Solenoid Valve shall be wired to the Releasing Control Panel according to information provided by the control panel manufacturer.

Standard Solenoid data (others are optional):

- Voltage: 24VDC
- Normally Position: NO (for Closed Main Deluge Valve when De-Energized)
- Enclosure Type: 1,2,3,3S, 4 and 4X/IP-65 (For Hazardous Locations enclosure, see catalog)
- Electrical Rating: 8 Watt

#### NOTES:

- Any deviation in trim size or arrangement may adversely affect the proper operation of the Deluge Valve.
- All initiating devices (detectors), indicating appliances, releasing devices, pilot line actuation devices (such as thermostatic releases, and/or fixed temperature releases), as well as the system control panel, must be compatible and UL listed for use with the particular Deluge System. Refer to current "UL Listed Fire Protection Equipment Directory". Refer also to NFPA 13 or the applicable installation standards, codes and authorities having jurisdiction.

**WARNING:** The Deluge Valve and trim must be installed only in areas where they will not be subjected to freezing temperatures.

Figure 1: Installation Drawing

**System Components**

- 1 - Main Valve, BERMAD 400E Series
- 2B - Accelerator with Priming Restriction
- 4B - Priming Strainer
- 6B - Pressure Operated Relief Valve (PORV)
- 7B - Check Valve
- 15B - Manual Emergency Release
- 18B - Priming Valve
- 24B - 3-way Solenoid

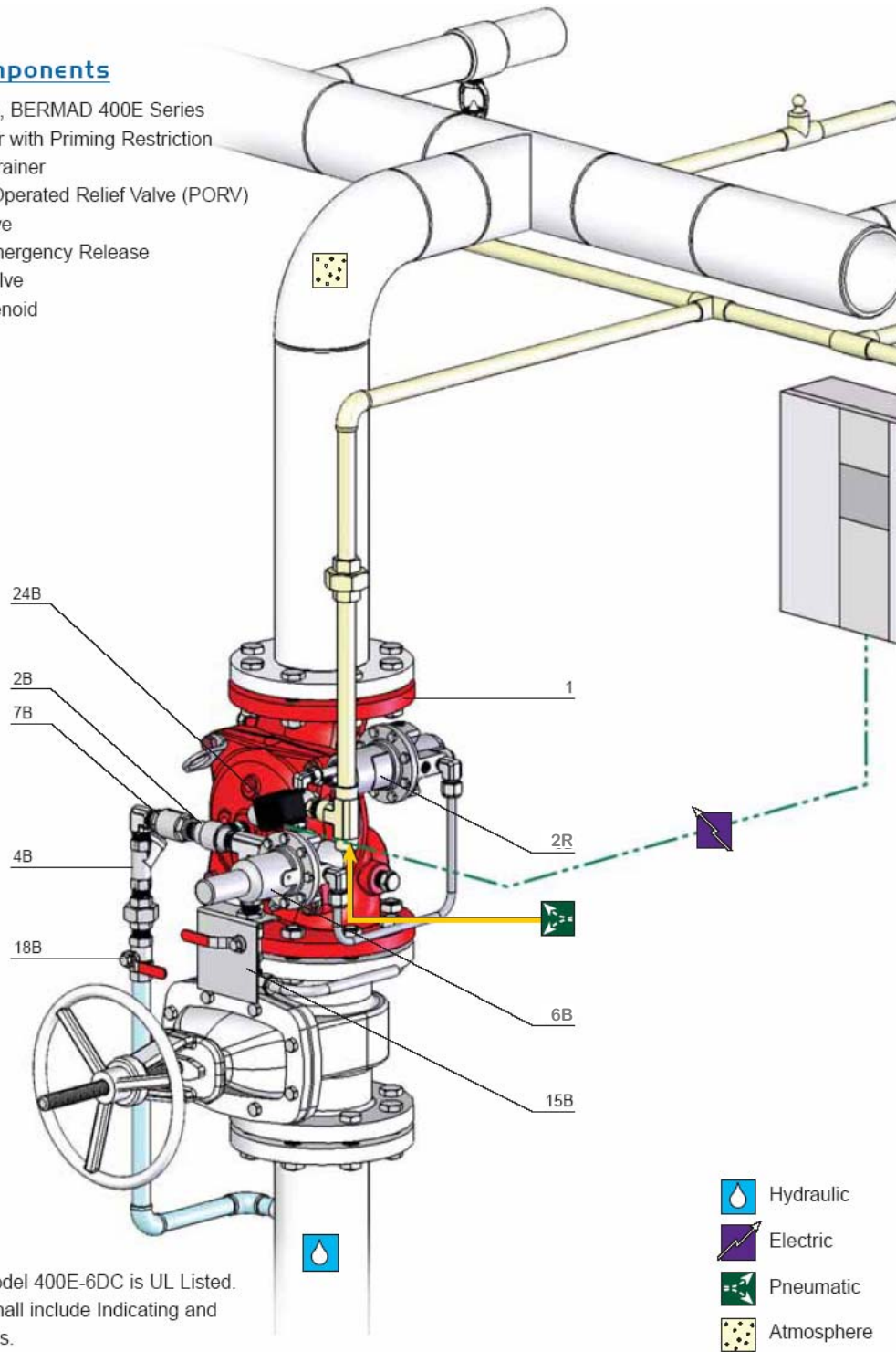

**Note**  
 The BERMAD Model 400E-6DC is UL Listed.  
 The installation shall include Indicating and Drain Components.



## 5. Equivalent Length

Deluge Valve Equivalent Length Value (Steel Pipe), for use in hydraulically calculated systems

Valve Size	Equivalent Length Value Meter (Ft)
2"	9.1 (30) of 2" pipe
2½"	12.1 (40) of 2½" pipe
3"	13.7 (45) of 3" pipe
4"	14 (46) of 4" pipe
6"	27.4 (90) of 6" pipe
8"	45.7 (150) of 8" pipe

## 6. Optional Equipment

- 6.1 If required, provide an Alarm Pressure Switch, to either activate an electric alarm, or shut down desired equipment. Connect it according to manufacturer instructions.
- 6.2 If required, provide a Water Motor Alarm, it shall be assembled and installed according to instructions with in its package.
- 6.3 It is a recommended practice to provide an "Inspector's Test Connection" on the hydraulic release system. The inspector's Test Connection should be equipped with a ball valve (normally locked closed) capable of being opened to simulate the opening of a release.

## 7. Placing in Service/Resetting the System

- 7.1. Place the detector circuit in service.
- 7.2. Reset the Solenoid Valve (24B fig.1) by resetting the releasing control panel
- 7.3. Operate pneumatic pressure supply system, allowing release system pressure to build up to a range of 20 to 30 psi (1.4 to 2.0 barg). Check the entire system for leaks
- 7.4. Check the entire Dry Pilot release system for leaks. Replace any fused plugs temperature-releases.  
**NOTE:** Any automatic air or nitrogen pressure supply must feed the system through an orifice restriction. If a low air pressure alarm is utilized, test it by dropping the release line pressure. Restore pressure after the test.
- 7.5. Close all emergency release valves.
- 7.6. Test supervisory circuits in releasing control panel.
- 7.7. Open the priming-line valve (18B fig.1). Check that there is no water flow from the PORV (6B fig.1). Allow pressurized water to fill the top chamber of the Deluge Valve.
- 7.8. When the control chamber pressure gauge indicates full upstream pressure and is no longer rising, the release system is reset.
- 7.9. Slowly Open the supply Isolating Valve and check that no water flows into the system.
- 7.10. Depress the Drip Check and drain any water from the system side of the Deluge Valve.

The system is now operational and in a standby mode.  
Ensure that the following Set Conditions are met.

## Set Conditions (Normal Conditions)

Item	Status
All Main Isolating Valves	<b>OPEN</b> and sealed with tamperproof seals
All Manual Releases	<b>CLOSE</b> position and sealed
Alarm Shut-Off Valve	<b>OPEN</b> position
Priming Ball Valve (18B fig.1)	<b>OPEN</b>
Control-Chamber Gauge	<b>OPEN</b> gauge valve, the Pressure Gauge indicates rate of pressure in Control-Chamber
Upstream Pressure Gauge	<b>OPEN</b> gauge valve, the Pressure Gauge indicates the upstream supply pressure to the Deluge Valve
Drip-Check Device	<b>VENTED</b> : Push the knob to confirm that there is no leakage.
Control Panel & Detections	Are in service and its stand-by position.
Releasing Devices	<b>CLOSED</b> with no leaking

## 8. Removing the System from Service

When taking the Deluge System out of service, a fire patrol should be established in the system area. If automatic fire-alarm signaling equipment is utilized, the proper authority should be notified that the system is being removed from service. The insuring body and owner representative should also be notified when the system is being taken out of service.

## 9. Removing Instructions

- 9.1. Shut off the main supply-isolating valve.
- 9.2. Close the Priming line valve (18B fig.1) to Deluge Valve Control chamber.
- 9.3. Open all drain valves.
- 9.4. Release the water pressure from the control chamber of the Deluge Valve by pulling the Manual emergency release (15B fig.1).
- 9.5. Shut off air or nitrogen supply to the release system
- 9.6. Release air or nitrogen pressure from the release system. This may be accomplished by tripping a release or opening a test valve in the release system.
- 9.7. If auxiliary power is used, disconnect the power supply and batteries.
- 9.8. Place "Fire Protection System out of Service" signs in the area protected by the system.

## 10. Operation

Bermad Deluge Valve prevents water from entering system piping until required. The Deluge Valve is kept closed by pressure applied to the top chamber through a restricted priming line.

In the SET position the water pressure supplied through the priming line is trapped in the top chamber of the Deluge Valve by the check valve (7B fig.1) and the Normally Held Closed PORV (6B fig.1)

The PORV is held closed by regulated external actuating pressure maintained in the pneumatic supply system by the normally opened solenoid valve (24B fig.1).

The pressure trapped in the top chamber of the Deluge Valve presses the valve seal disc down, sealing the valve and keeping the system piping dry.

In FIRE conditions, when the pressure is released from the top chamber, by the PORV in combination with the energized Solenoid Valve or by manual release, faster than it is supplied through the restricted priming line, the

Deluge Valve opens and allows the inlet supply water to flow through the valve into the system and alarm devices.

**WARNING:** Whenever the handle of the Manual Emergency Release (15B fig.1) is pulled, pressure is released from the top chamber, the Deluge Valve will open, and water will flow into system piping and alarm devices.

## 11. Manual Operation

Whenever the handle of the Manual Emergency Release is pulled, pressure is released from the top chamber, the Deluge Valve will open, and water will flow into system piping and alarm devices.

**Note:** The Manual Emergency Release (15B fig.1) overrides the PR pilot, causing the 400E-5DC to open fully.

### Air Supply Troubles

Any event of an air supply failure, slow leakage of air from the pneumatic release system, and/or failure to restore air supply to the pneumatic release system, will result in activation of the Pneumatic PORV, causing the Deluge Valve to open. Similarly, if the release system is activated due to mechanical damage or malfunction, the Deluge Valve will open. Water will flow from any open sprinklers and/or spray nozzles on the system. Water Motor Alarm (will be set off).

Figure 2: Operation Drawing

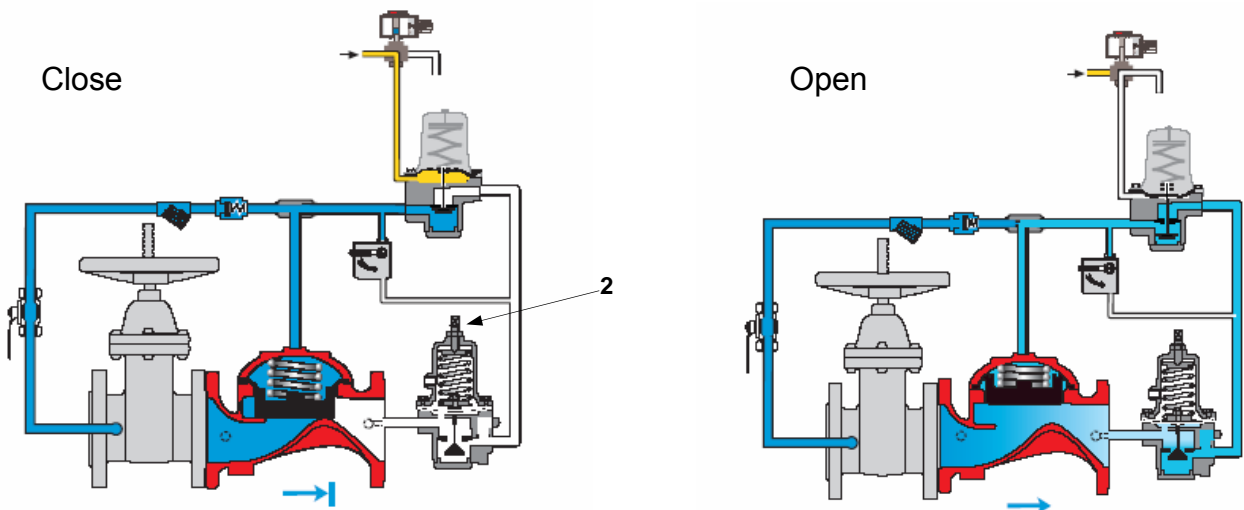



## 12. Maintenance and Inspection Test

Warning: Do not turn off the water supply to make repairs without placing a roving fire patrol in the area covered by the system. The patrol should continue until the system is back in service.

- 12.1. Prior to turning off any valves or activating any alarms, notify local security guards and the central alarm station, if used, so that a false alarm will not be signaled.
- 12.2. In any of the following inspections or testing procedures, if an abnormal condition exists, see Abnormal Conditions for possible cause and corrective action.
- 12.3. See NFPA Pamphlet No. 25 and also relevant publications by authorities having jurisdiction. Weekly Inspection.
- 12.4. The system should be checked for Set Condition. See below "Set Condition (Normal condition)".
- 12.5. Observe the upstream pressure gauge: it should indicate that the normal supply of water pressure to the Deluge Valve is maintained.

### Readjusting

The pilot valve is factory pre-set according to the stated demands of the customer. The pre-set is clearly indicated on the pilot valve tag.

If readjustment to either the pressure or valve response is required, follow the following steps.

1. Ensure that there is minimum flow through the main valve.(for Pilot setting flow rate see Table1, item Minimum flow rate for pilot setting.)
2. Free the tension between the adjusting screw on the pressure reducing pilot valve (2 in figure 2) and the fastening nut by turning the fastening nut counterclockwise.
3. By alternately turning the adjusting screw on the pilot valve a half turn and then reading the downstream pressure, gradually adjust the pressure:
  - Counterclockwise to decrease (-) the downstream pressure
  - Clockwise to increase (+) the downstream pressure.

## 13. Normal Conditions

Ensure that the following Set Conditions are met.

Item	Status
All Main Isolating Valves	OPEN and sealed with tamperproof seals
All Manual Releases	CLOSE position and sealed
Alarm Shut-Off Valve (11A fig.1)	OPEN position
Priming Ball Valve (18B fig.1)	OPEN
Control-Chamber Gauge	OPEN gauge valve, the Pressure Gauge indicates pressure in the Control-Chamber
Upstream Pressure Gauge	OPEN gauge valve, the Pressure Gauge indicates the upstream pressure of the Deluge Valve
Control Panel & Detections	Are in service and its stand-by position.



Pneumatic Release System	20 to 30 psi (1.4 to 2.0 barg) is maintained, pressure supply system is ON and functioning properly
Releasing Devices	CLOSED with no leaking

## Pneumatic Release System

1. The Pneumatic Release System Pressure Gauge should indicate 20 to 30 psi (1.4 barg to 2.0 barg).
2. Pneumatic pressure supply system (including its dehydrator) is functioning properly.
3. Automatic air or nitrogen-supply is ON, compressor is ON.

## 14. Weekly Inspection

- 14.1. The system should be checked for Set Condition. See above "Set Condition (Normal condition)".
- 14.2. Observe the upstream pressure gauge, it should indicate that the normal supply of water pressure to the Deluge Valve is maintained

## 15. Monthly Inspection and Test

- 15.1. Complete Weekly Inspection.
- 15.2. Test the water-motor alarm and/or electric alarm (if installed), by turning the alarm test valve to the open position. The alarm should sound. Turn to close position
- 15.3. Inspect the electric detection system and electric release control panel, as suggested by the release control panel manufacturer
- 15.4. Inspect the Pneumatic release system (if utilized), Drain condensation from release-lines and service the dehydrator if necessary.

## 16. Annual Inspection and Test

- 16.1. Complete Weekly, Monthly and Semi-Annual inspections
- 16.2. Place the system out of service (See "Removing The System From Service" above).
- 16.3. Trip the release-line system, clean all strainers (4B fig.1), and priming-line restriction.
- 16.4. The interior of the Deluge Valve should be cleaned and inspected.
- 16.5. The interior of the PORV (6B fig.1), including its diaphragm and seal, should be inspected and cleaned.
- 16.6. Place the system back in service. (See instructions "Placing the System in Service").
- 16.7. The Deluge Valve, trim, auxiliary devices and manual release must be activated at full flow.
- 16.8. Note: The system will be flooded! Take all necessary precautions to drain water and prevent damage in the area protected by the Deluge system.
- 16.9. Trip-test the deluge system with an electric release control panel. The release may be tripped by the method suggested by the release control panel manufacturer
- 16.10. Trip test the deluge system by decreasing pressure in the pneumatic release system.
- 16.11. The manual emergency release handle (15B fig.1) is to be pulled. The Deluge Valve should open and discharge water. Observe upstream Pressure Gauge while full flow is on. Inspect all system nozzles.
- 16.12. Take all additional measures as required by NFPA-25 "Standard for the Inspection Testing and Maintenance of Water-Based Fire Protection Systems."
- 16.13. Clean the priming strainer (4B fig.1) prior to resetting the Deluge Valve

## 17. Abnormal Conditions

### 17.1. Alarm Pressure Switch Fails to Sound

- A. Check for obstructions in the alarm test line.
- B. Clean the alarm-line strainer (if a water motor alarm is installed).
- C. Make certain the alarm is free to operate.
- D. Test the electrical circuit to the electric alarm (if utilized)

### 17.2. False Trip

Check for any of the following possible causes:

- A. Check and test the electrical circuit to the Solenoid Valve (14B fig.1).
- B. Check for Malfunctioning Air release system.
- C. PORV (6B fig.1) out of order.

### 17.3. Leakage through Deluge Valve

Check for any of the following possible causes:

- A. Check for clogged priming strainer (4B fig.1) or plugged priming restriction.
- B. Inadequate Pneumatic Pressure supply on relies system (pneumatic).
- C. Leaking control trim.
- D. Leaking Dry Pilot release system.
- E. Damaged deluge valve internal Elastomers or seat.
- F. PORV (6B fig.1) out of order.

### 17.4. Deluge Valve Will Not Reset

Check for any of the following possible causes:

- A. An open main control valve.
- B. Release system not properly drained.
- C. Inadequate Pneumatic Pressure supply.
- D. Check for clogged priming strainer (4B fig.1), the screen should be properly cleaned.
- E. Closed priming valve (18B).
- F. Check for Foreign object lodged between seal and valve seat.
- G. Control Panel is not reset. Check for Faulty circuits, using manufacturer instructions.
- H. Leak in Dry Pilot Line release system.

### 17.5. Electric Release System Will Not Reset

- A. Faulty Detector Circuit
- B. Faulty circuit to the Solenoid Valve (24B fig.1) or Release Control Panel.
- C. Observe if the Pressure Switch Cock Valve is open.

17.6. Where difficulty in performance is experienced, BERMAD or its authorized representative should be contacted if any field adjustment is to be made.