



Maintenance Instructions

Backwash Filter Valve

Model 350-3x3



1 | Disassembling the actuator from the valve

A.

Disconnect the control tube.



B.

Turn the actuator counter clockwise.
(If necessary, use a suitable wrench or spanner.)



C.

Pulling gently upwards, slide the actuator out of the valve body.



2 | Replacing the seal

A.

Using two 13/19mm wrenches, release the closure locking nut.



B.

Remove the plug washer and then remove the seal. Check the condition of the seal and replace as required.



C.

Replace the components of the closure assembly in the order shown here, from bottom to top. Pay attention to the position of the parts and their direction according to the different models (Angular model - black cover; Straight model - gray cover).

Angle Flow Model

- 15 | Nut
- 18 | Disc
- 05 | Black Plug
- 04 | Dynamic Seal
- 20 | O-Ring
- 02 | Gray Plug
- 18 | Disc



Straight Flow Model

- 15 | Nut
- 18 | Disc
- 02 | Gray Plug
- 04 | Dynamic Seal
- 20 | O-Ring
- 05 | Black Plug
- 18 | Disc



D.

Tighten the closure nut to ensure locking.
Use OMNIFIT 200M or similar glue



E.

Check the condition of the actuator O-ring
and replace as required.



F.

Apply a silicon lubricant on the O-ring
and thread when fitting the actuator
onto the valve body.



3. Replacing the diaphragm

A.

Using two 13mm wrenches, open the 12 bolts of the closure assembly.

- 14 | Bolt
- 16 | Disc
- 15 | Nut



B.

Remove the cover. Pay attention to the position of the parts and their direction according to the different models (Angular model - black cover; Straight model - gray cover).

Angle Flow Model

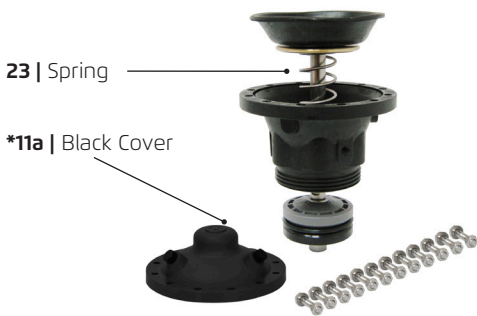

Straight Flow Model

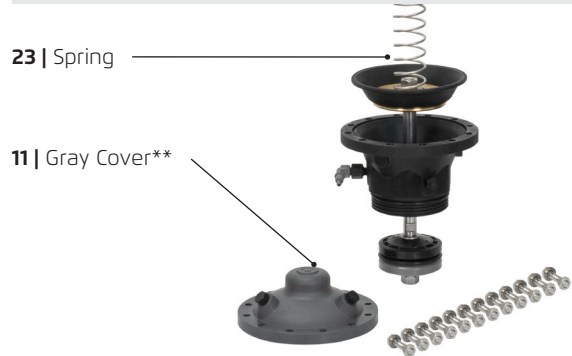

C.

Pulling gently, slide the shaft out of the separation partition.

Angle Flow Model



Straight Flow Model



D.

Open the locking nut with the aid of two wrenches - a 17mm spanner and 13mm spanner.



E.

Remove the diaphragm washer.
Check and replace diaphragm as required.



F.

Reassemble the diaphragm assembly, paying attention to the order of the parts and their position in accordance with the type of model.

Use a suitable type of glue to ensure locking of the shaft nut.



4. Replacing the Shaft Seals

A.

Using a suitable tool, remove both shaft O-rings from the separation partition. Replace them with new ones as required.



Use a silicon lubricant when reassembling the shaft.



5. Replacing the seats

A.

Using a suitable wrench, open the Cover Ring by turning clock-wise.



Straight Flow Model



31a | with 2" thread

Angle Flow Model



31c | lower adaptor groove

B.

Using a screwdriver, separate the valve body assembly from the lower adaptor assembly.



C.

Inspect the seats visually. In case of damage, go to next step (C).



D.

Ensure that O-Ring (26) is in place before closing.
Check the condition of the seat and of the seal, and replace as required.

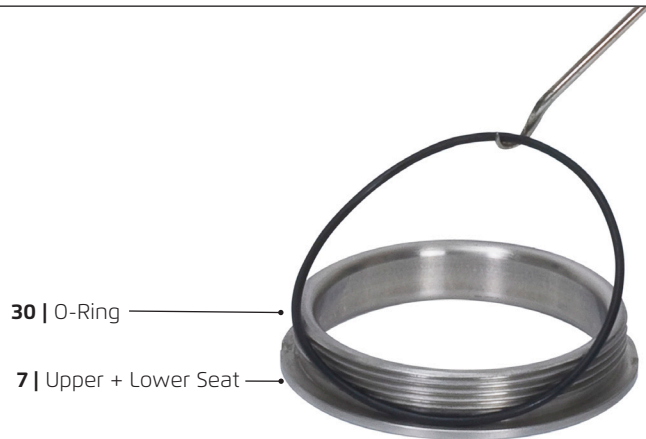

E.

Check the condition of the lower adaptor seal and replace as required.



F.

Reconnect the lower adaptor to the valve body.



Plastic Backwash Filter Valves, Double Chamber, Straight/Angle & Reverse Flow -

Model 350 3X3 (Page 10B in Bermad's Spare Parts Guide)

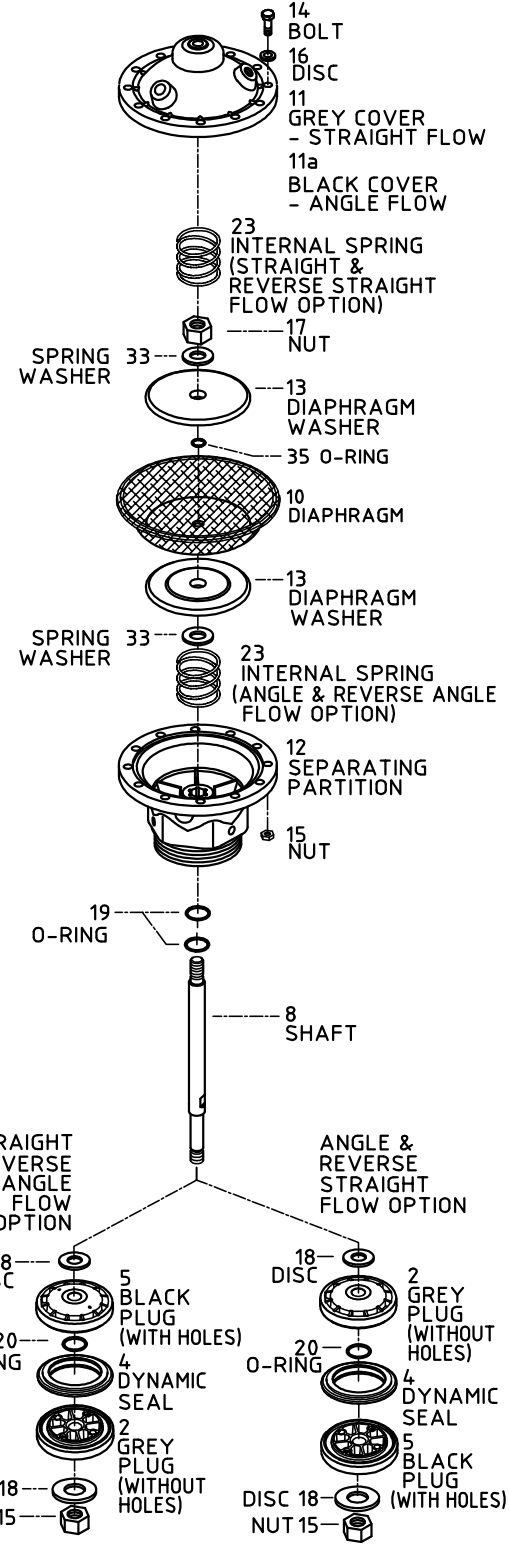
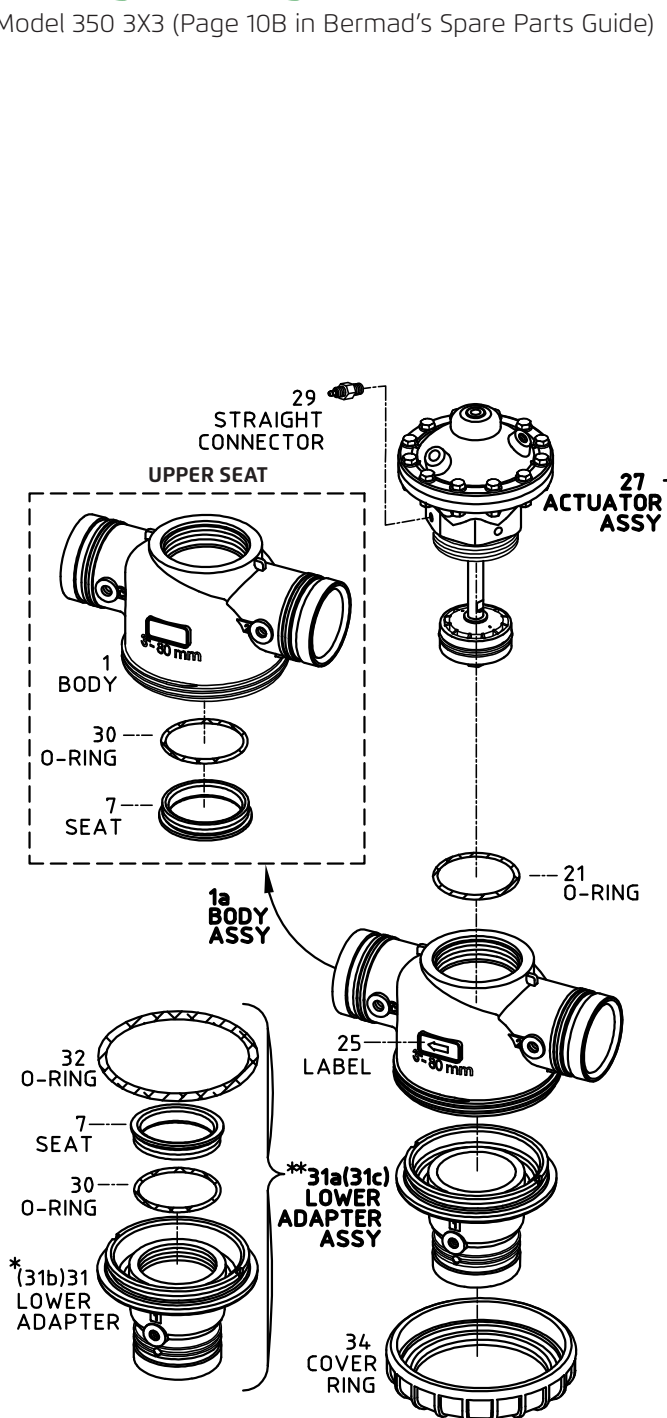

- * 31 - Lower Adapter with 2" thread (straight flow)
- 31b - Lower Adapter groove (angle flow)
- ** 31a - Lower Adapter assy with 2" thread (straight flow)
- 31c - Lower Adapter assy groove (angle flow)

When ordering please mention page no 10B

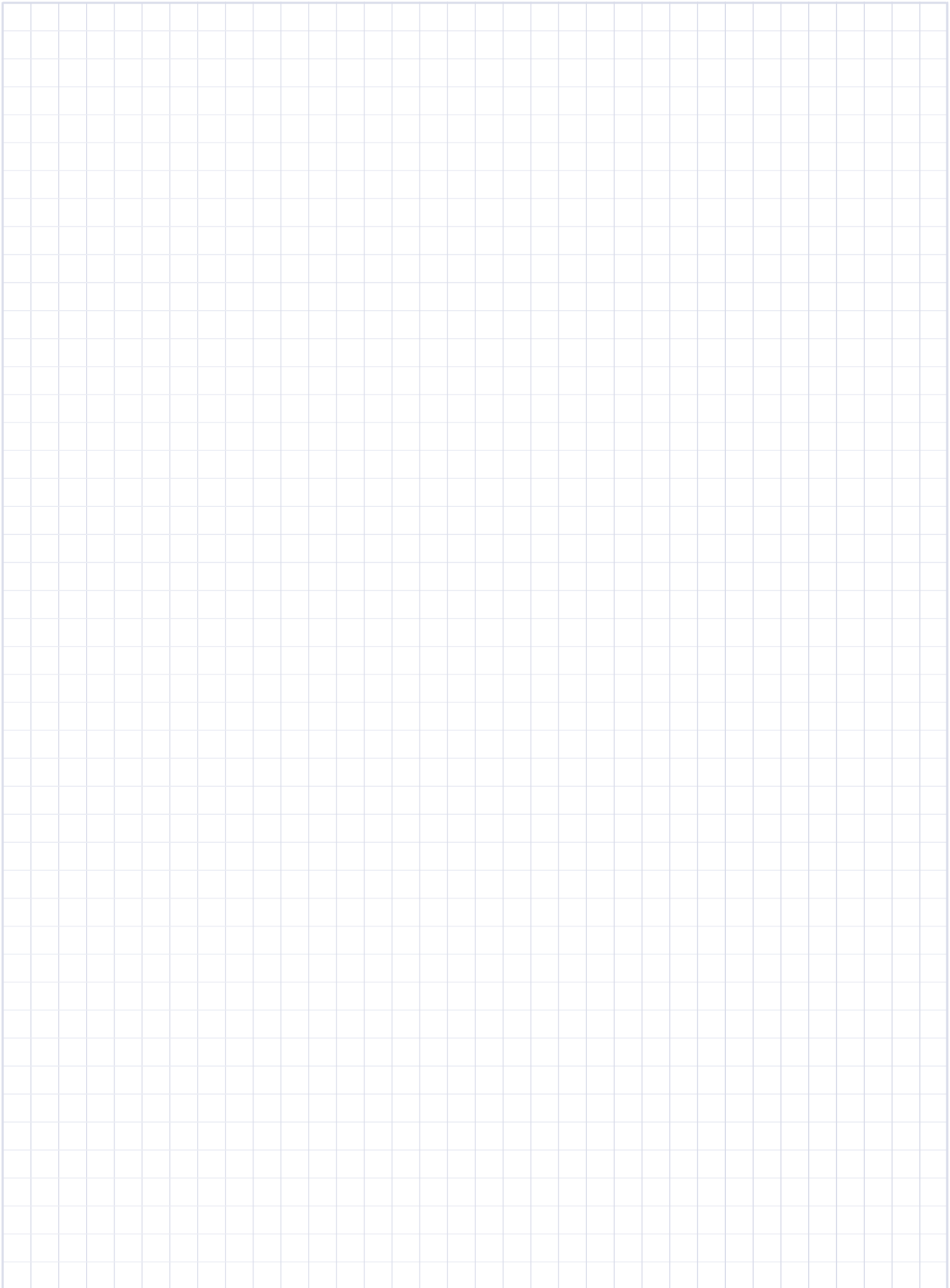



[ozbranding.co.il]



www.bermad.com

© Copyright 2007-2012 Bermad CS Ltd. All Rights Reserved. The information contained in this document is subject to change without notice. BERMAD shall not be liable for any errors contained herein.

PTWAE03 - Model 3x3 Rev. 1 April 2017