

Filter Backwash Hydraulic Valve

4X3 Metal

IR-4x3-350-A-I

The BERMAD Model IR-4x3-350-A-I is a compact 3-port valve, in a T configuration. It is single chambered, hydraulically operated and diaphragm actuated with an angled flow. The valve is designed for automatic backwashing of filtration systems where the filter supply port is vertical to the supply manifold.



Features and Benefits

- Line Pressure Driven
- Hydro-Efficient Design
 - Single moving part
 - Unobstructed flow path
 - High flow capacity
- Fully Supported & Guided Diaphragm
 - Prevents diaphragm distortion
- Dynamic Sealing
 - Seals at very low pressure
 - Prevents seal friction and erosion
- Cast Iron Body
 - Rigid construction, high stress resistance
- Short Valve Travel
 - Smooth changes of flow direction
 - Eliminates mixing of supply and waste water
- User-Friendly
 - Can be installed in various orientations
 - Simple in-line inspection and service

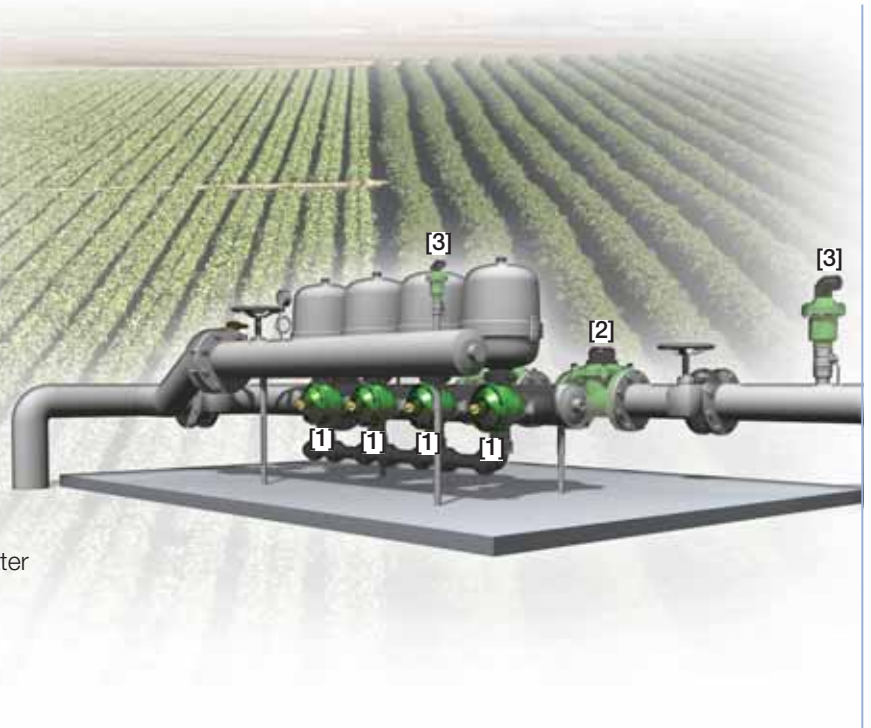

Typical Applications

- Automatic Backwash of Filter Batteries
 - Gravel Filters
 - Sand Filters
 - Disk Filters
 - Screen Filters
- Angled Installations

[1] BERMAD Model IR-4x3-350-A-I allows flow into the filter, and switches closed upon pressure rise command, thereby blocking inlet to filter and enabling backwash flow from the filter.

[2] BERMAD Water Meter Model WPH

[3] BERMAD Air Valve Model ARC-A-I-I

BERMAD Irrigation



IR-4x3-350-A-I

For full technical details, refer to Engineering Section.

350 Series

Filter Stations

Technical Specifications

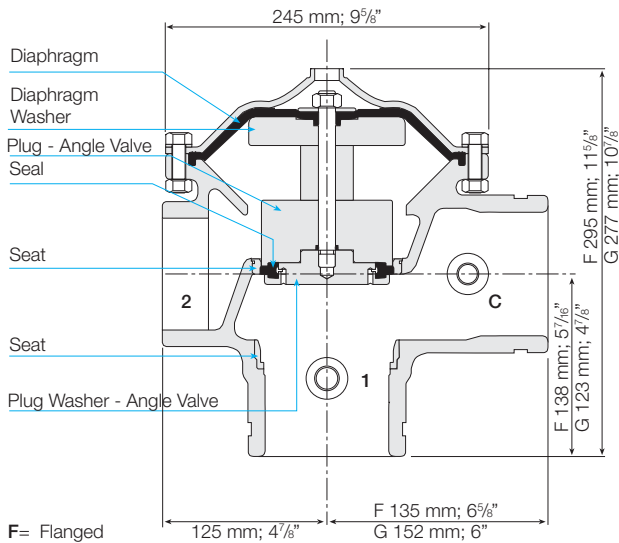

F= Flanged
G= Grooved

Weight:

Flanged 39.0 Kg; 86.0 lbs.

Grooved 21.0 Kg; 46.3 lbs

Technical Data

Control Chamber Displacement Volume: 1.055 liter; 0.29 gallon

Operating Pressure: 0.7-16 bar; 10-232 psi

External Operating Pressure: 100% of operating pressure

Maximum Temperature: 65°C; 150°F

End Connections: Inlet & Outlet: Flanged, Grooved Drain: Threaded

Flow Pattern: Angled Flow

Materials

Valve Body: Polyester or Epoxy coated Cast Iron

Cover: Epoxy coated Carbon Steel

Diaphragm: NR-AL52 Nylon Fabric Reinforced

Seats, Diaphragm Washers: Brass

Plug, Plug Washer: Acetal Copolymer Black

Seal, O-Rings: NBR

Shaft: Stainless Steel AISI 303

External Bolts, Studs, Nuts & Disks: Stainless Steel

Hydraulic Data

	Filtration 1⇒C		Backwash C⇒2	
Angle Flow				
	Kv=212	Cv=245	Kv=106	Cv=122

$$\Delta P = \left(\frac{Q}{Kv}\right)^2$$

Kv = m³/h @ ΔP of 1 bar

Q = m³/h

ΔP = bar

$$\Delta P = \left(\frac{Q}{Cv}\right)^2 \Delta$$

Cv = gpm @ ΔP of 1 psi

Q = gpm

ΔP = psi

Cv = 1.155 KV

Operation

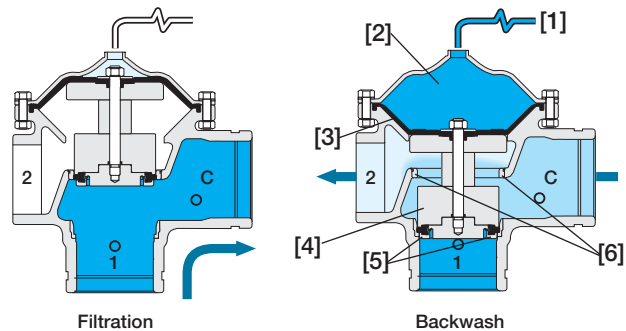

A Hydraulic Command [1], which pressurizes the Control Chamber [2], forces the Diaphragm [3] actuated Plug Assembly [4] to move towards the Supply Port Seat [5], eventually sealing it drip tight. This allows flow from the filter through the Drain Port Seat [6]. During Valve closing, the Plug [7] blocks the drain port seat, preventing mixing of supply water with waste water. Venting the control chamber causes the line pressure to move the Valve back to filtration mode.

How to Order

Please specify the requested valve in the following sequence: (for more options, refer to Ordering Guide.)

Sector	Size	Primary Feature	Additional Feature	Pattern/ Flow Option	Construction Materials	Drain Connections	End Connections	Additional Attributes	Coating	Voltage & Position	Tubing & Fittings
IR	4X3	350	00	A	I	P	VI	-	PG	00	PB
	Angle Flow	A	Threaded BSP Threaded NPT	P N	Grooved ANSI C 606-81 ISO-14 (ISO-10/4 Holes) ANSI-125 BST-D	VI 14 A1 BD	Polyester Green RAL 6017 Polyester Blue RAL 5010 Polyester Red RAL 3000	PG PB PR	Plastic Tubing & Fittings Plastic Tubing & Brass Fittings	PP PB	

Other Flange Standards available.



info@bermad.com • www.bermad.com

The information herein is subject to change without notice. BERMAD shall not be held liable for any errors. All rights reserved. © Copyright by BERMAD.

PCWAE43 05