



Check Valve

Lift Type

- Pump check valve
- One-way zone isolation
- Return flow prevention

The Model 70N Check Valve is a non-slam, lift type, non return valve that opens to allow flow in the required direction and smoothly closes drip tight to prevent back flow.



Features and Benefits

- **Non-slam closing** – Eliminates system surges
- **In-line serviceable** – Easy maintenance
- **Flexible design** – Convertible to hydraulic valve
- **"Y" or angle, wide body** – Minimized pressure loss
- **Semi-straight flow** – Non-turbulent flow
- **Stainless Steel raised seat** – Cavitation damage resistant
- **Obstacle free, full bore** – Uncompromising reliability

Major Additional Features

- Valve position indicator – 70N-I
- Electric limit switch – 70N-S
- Double check valve – 72N

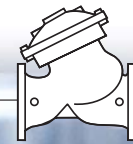

Operation

The Model 70N is built on a standard 700 Series body assembly and reacts to differential pressure across its seal disk. It opens and closes in a non-slam manner according to the flow. A spring provides additional closing force.

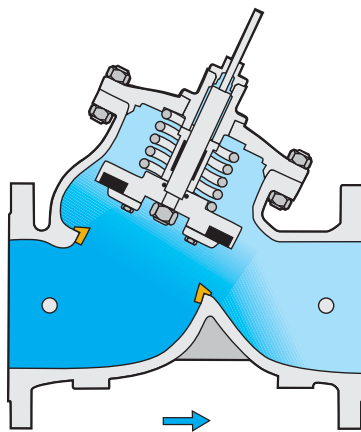

Normal flow

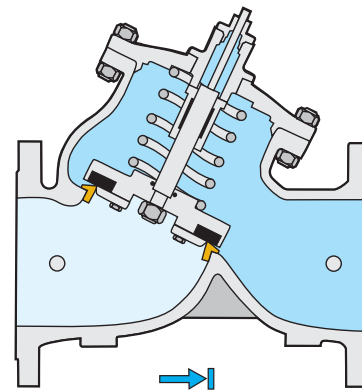

Back flow prevented

Engineer Specifications

The Check Valve shall open to allow flow in the required direction and close drip-tight with no slam to prevent back flow.

Main Valve: The main valve shall be a globe valve of either oblique (Y) or angle pattern design. The body shall have a replaceable, raised, stainless steel seat ring. The body and cover shall be ductile iron. All external bolts, nuts, and studs shall be Duplex® coated. All valve components shall be accessible and serviceable without removing the valve from the pipeline.

Actuator: The entire internal assembly (seal disk to cover) shall be removable from the valve. The stainless steel valve shaft shall be center guided by a bearing in the cover and shall accept a valve position indicator with limit switch. The replaceable radial seal disk shall include a resilient seal.

Quality Assurance: The assembled valve shall be hydraulically tested. The valve manufacturer shall be certified according to the ISO 9001 Quality Assurance Standard. The valve shall be certified as a complete drinking water valve according to NSF, WRAS, and other recognized standards.

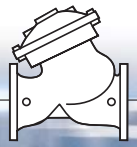

Typical Applications

One-Way Zone Isolation

In complex distribution networks, multiple zones are supplied from multiple sources. Each zone has its own characteristic demands and each source has its characteristic capacity. Often each source is designated to serve a specific zone, with a backup supply designed into the system.

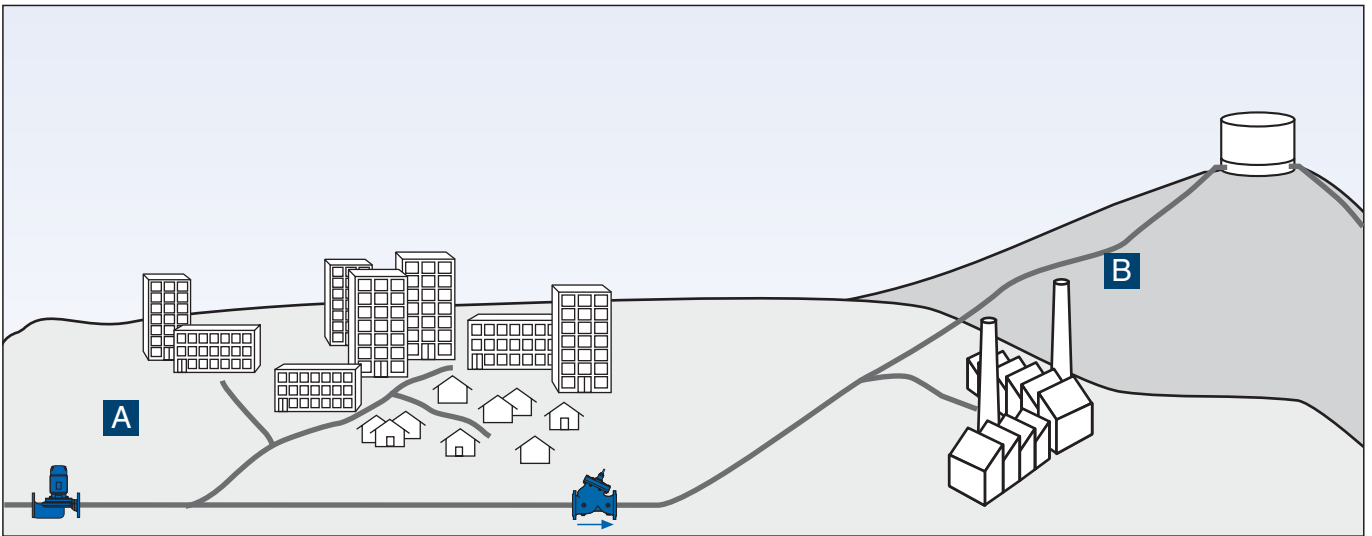

In this system, source **A** supplies zone **A** and backs up the farther zone. Source **B** supplies zone **B**, but does not have enough capacity to backup any other zone.

The Model 70N Check Valve, installed between the zones, allows flow from source **A** to zone **B**, but not from source **B** to zone **A**.

Pump Check Valve

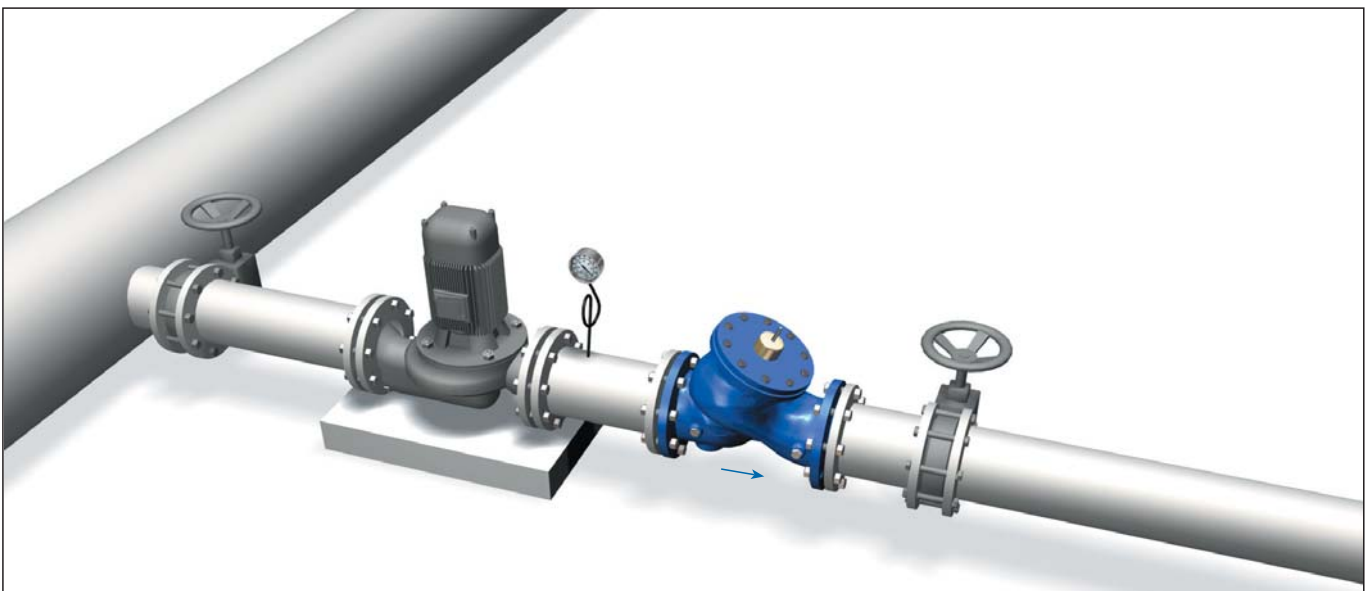



Technical Data

Dimensions and Weights

Size	L		L1		H		W		W1		C		
mm inch	mm	inch	mm	inch	mm	inch	kg	lbs	kg	lbs	mm	inch	
40	1 1/2"	205	8.1	205	8.1	125	4.9	7.0	15.4	9.0	19.8	180	7
50	2	210	8.3	210	8.3	125	4.9	8.0	17.6	10	22	180	7
65	2 1/2"	222	8.7	222	8.7	125	4.9	11	24.3	14	30.9	180	7
80	3"	250	9.8	264	10.4	170	6.7	18	39.7	21	46.3	230	9
100	4"	320	12.6	335	13.2	210	8.3	30	66.1	36	79.4	275	11
150	6"	415	16.3	433	17.0	270	10.6	52	115	62	137	385	15
200	8"	500	19.7	524	20.6	330	13.0	85	187	106	234	460	18
250	10"	605	23.8	637	25.1	420	16.5	147	324	175	386	580	23
300	12"	725	28.5	762	30.0	480	18.9	254	560	295	650	685	27
350	14"	733	28.9	767	30.2	480	18.9	265	584	318	701	685	27
400	16"	990	39.0	1024	40.3	620	24.4	575	1268	630	1389	965	38
450	18"	1000	39.4	1030	40.5	620	24.4	690	1521	775	1708	965	38
500	20"	1100	43.3	1136	44.7	620	24.4	800	1764	890	1962	965	38

L, W – ISO 10 & 16; ANSI 150

L1, W1 – ISO 25; ANSI 300

"L", ISO standard lengths available

"C" enables removing the actuator in one unit

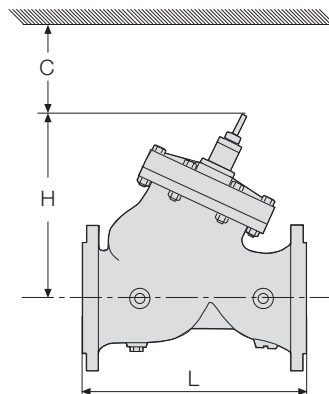

Specifications

Patterns: "Y" (globe) & angle

Size Range: 1 1/2" - 20" (40-500 mm)

End Connections (Pressure Ratings):

Flanged: ISO PN16, PN25

(ANSI Class 150, 300)

Threaded: BSP or NPT

Others: Available on request

Working Temperature:

Water up to 80°C (180°F)

Standard Materials:

Body: Ductile Iron

Cover: Steel

Internals:

Stainless Steel, Bronze,

coated Steel & Delerine

Seals: NBR

Coating:

Fusion Bonded Epoxy, RAL 5005 (Blue)

NSF & WRAS approved or Electrostatic

Polyester Powder, RAL 6017 (Green)

Flow Chart

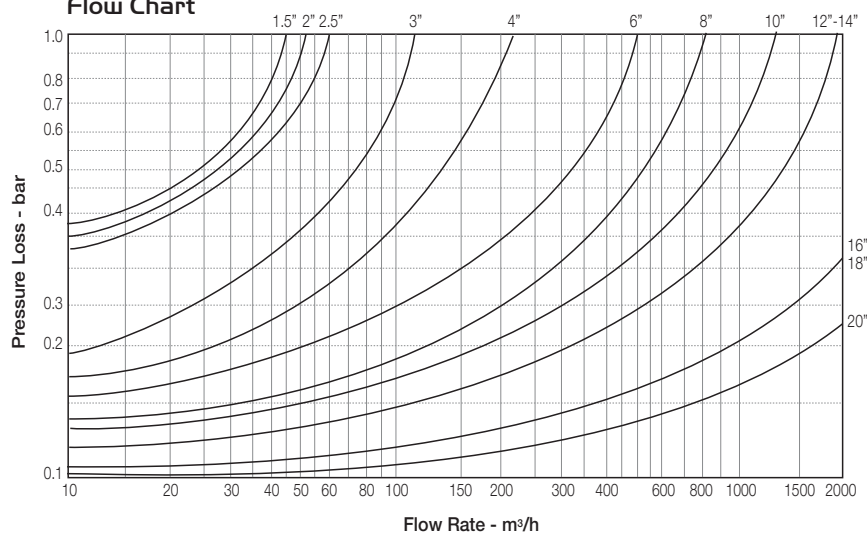

How to Order

Sector	Size	Primary Feature	Pattern	Body Material	End Connections	Coating	Additional Attributes
WW	6"	70N	Y	C	16	EB	I
Waterworks	1 1/2" - 20"	Check valve	Oblique (up to 20") Angle (up to 18")	Ductile Iron Standard Cast Steel St. Steel 316	ISO-16 16 ISO-25 25 ANSI-150 A5 ANSI-300 A3 JIS-16 J6 JIS-20 J2	Epoxy FB Blue EB Polyester Green PG Polyester Blue PB Uncoated UC	Valve Position Indicator I Electric Limit Switch S

