

Level and Flow Control Valve with Bi-Level Vertical Float

- Reservoir level control
- Prioritizing consumers over reservoir filling
- Backup for reservoir supply valves
- Integral valve cavitation protection

The Model 757-66-U Level and Flow Control Valve with Bi-Level Vertical Float is a hydraulically operated, diaphragm actuated control valve that controls reservoir filling. The valve hydraulically opens at pre-set low level and shuts off at pre-set high level. During filling, it limits the flow to preset maximum, regardless of fluctuating upstream pressure or reservoir level.



Features and Benefits

- **Line pressure driven** – Independent operation
- **Bi-Level hydraulic float control**
 - On/Off service
 - Low cavitation damage
 - Reservoir inherent refreshing
- **Hydraulic flow sensor (downstream installation)**
 - No moving parts
 - No electronic components
 - Wide flow setting range
 - Cavitation damage protection
- **Double chamber design**
 - Moderated valve reaction
 - Protected diaphragm
- **External installation**
 - Easy access to valve and float
 - Easy level setting
- **In-line serviceable** – Easy maintenance
- **Flexible design** – Easy addition of features

Major Additional Features

- Closing surge prevention – 757-66-49-U
- Hydraulic float backup – 757-66-65-U
- Altitude pilot backup – 757-66-80-U

See relevant BERMAD publications.



Operation

The Model 757-66-U is a float and pilot controlled valve.

The float [1] slides along the rod [2]. When the float reaches either the adjustable high [3] or low [4] level stoppers, it either pushes the rod assembly up or pulls it down, switching the float pilot [5] position. When the float is between the adjustable stoppers, the main valve remains in its last position. The needle valve [6] continuously allows flow from valve inlet into the upper control chamber [7]. The Pressure Reducing (PR) pilot [8], and the Hydraulic Relay Valve (HRV) [9], together control outflow from the upper control chamber.

At high level, the float pilot applies pressure to the HRV control chamber closing it and causing the main valve to shut off.

At low level, the HRV opens, leaving the PR pilot to modulate the main valve open according to orifice [10] upstream pressure. Should this pressure rise above pilot setting, the PR pilot throttles, causing the main valve to throttle closed. Orifice upstream pressure is reduced to pilot setting, limiting the flow.

The needle valve controls the closing speed. The downstream cock valve [11] enables manual closing.

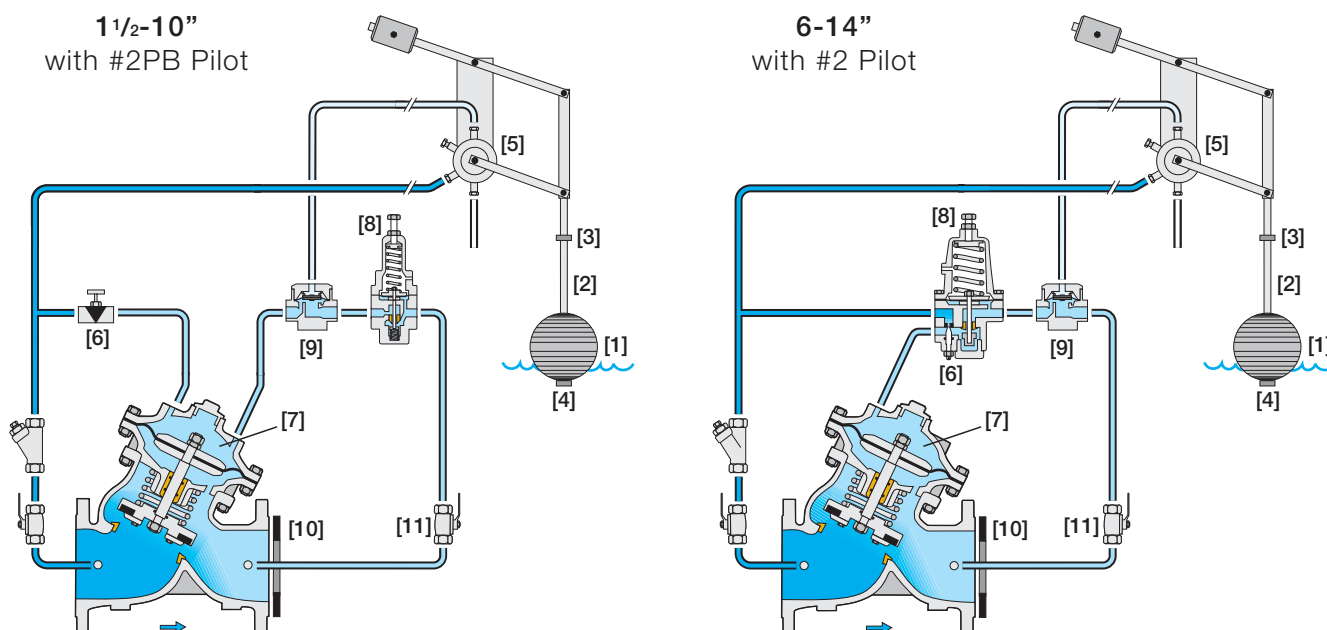

Note: For 16" and larger valves see "Pilot Valve Selection" table at the last page of Model 720.

Engineer Specifications

The Level & Flow Control Valve with Bi-Level Vertical Float shall control reservoir filling, opening at pre-set low level and shutting off at pre-set high level. During filling, it shall limit the flow to pre-set maximum regardless of fluctuating upstream pressure or reservoir level.

Main Valve: The main valve shall be a center guided, diaphragm actuated globe valve of either oblique (Y) or angle pattern design. The body shall have a replaceable, raised, stainless steel seat ring. The valve shall have an unobstructed flow path, with no stem guides, bearings, or supporting ribs. The body and cover shall be ductile iron. All external bolts, nuts, and studs shall be Duplex® coated. All valve components shall be accessible and serviceable without removing the valve from the pipeline.

Actuator: The actuator assembly shall be double chambered with an inherent separating partition between the lower surface of the diaphragm and the main valve. The entire actuator assembly (seal disk to top cover) shall be removable from the valve as an integral unit. The stainless steel valve shaft shall be center guided by a bearing in the separating partition. The replaceable radial seal disk shall include a resilient seal and shall be capable of accepting a V-Port Throttling Plug by bolting.

Control System: The control system shall consist of a 4-Way, "last position", adjustable, bi-level, hydraulic, vertical float, a 2-Way adjustable direct acting pressure reducing pilot valve, a hydraulic relay valve, a needle valve, isolating cock valves, a filter, and a stainless steel downstream orifice plate. All fittings shall be forged brass or stainless steel. The assembled valve shall be hydraulically tested and factory adjusted to customer requirements.

Quality Assurance: The valve manufacturer shall be certified according to the ISO 9001 Quality Assurance Standard. The main valve shall be certified as a complete drinking water valve according to NSF, WRAS, and other recognized standards.

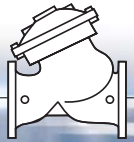

Typical Applications

Gravity Fed Lines

Alternative solutions to accommodate the obvious pressure reducing requirements associated with high elevation differential pipelines are:

- Pressure-reducing valves in series (see BERMAD's publication: Proportional Pressure Reducing Valve, Model 720-PD)
- Sequential pressure breaking reservoirs

Where pressure breaking reservoirs already exist or are specified, some issues to consider are:

- Pipeline problems associated with line emptying and filling
- Valve cavitation damage
- Reservoir high pressure flow jets

The Model 757-66-U is well suited to provide the solutions to these issues.

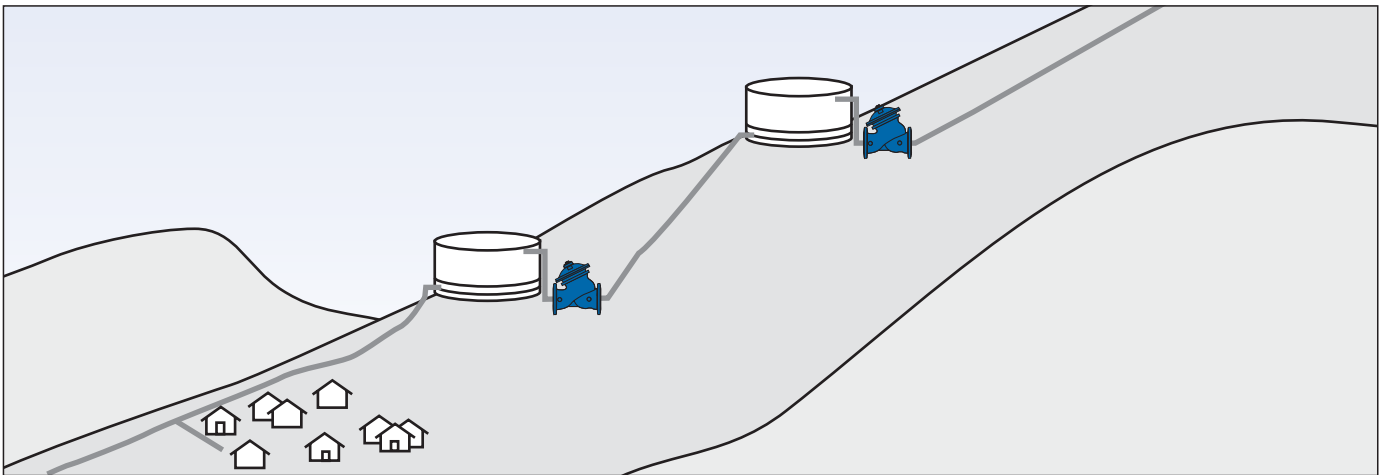

Typical Installation

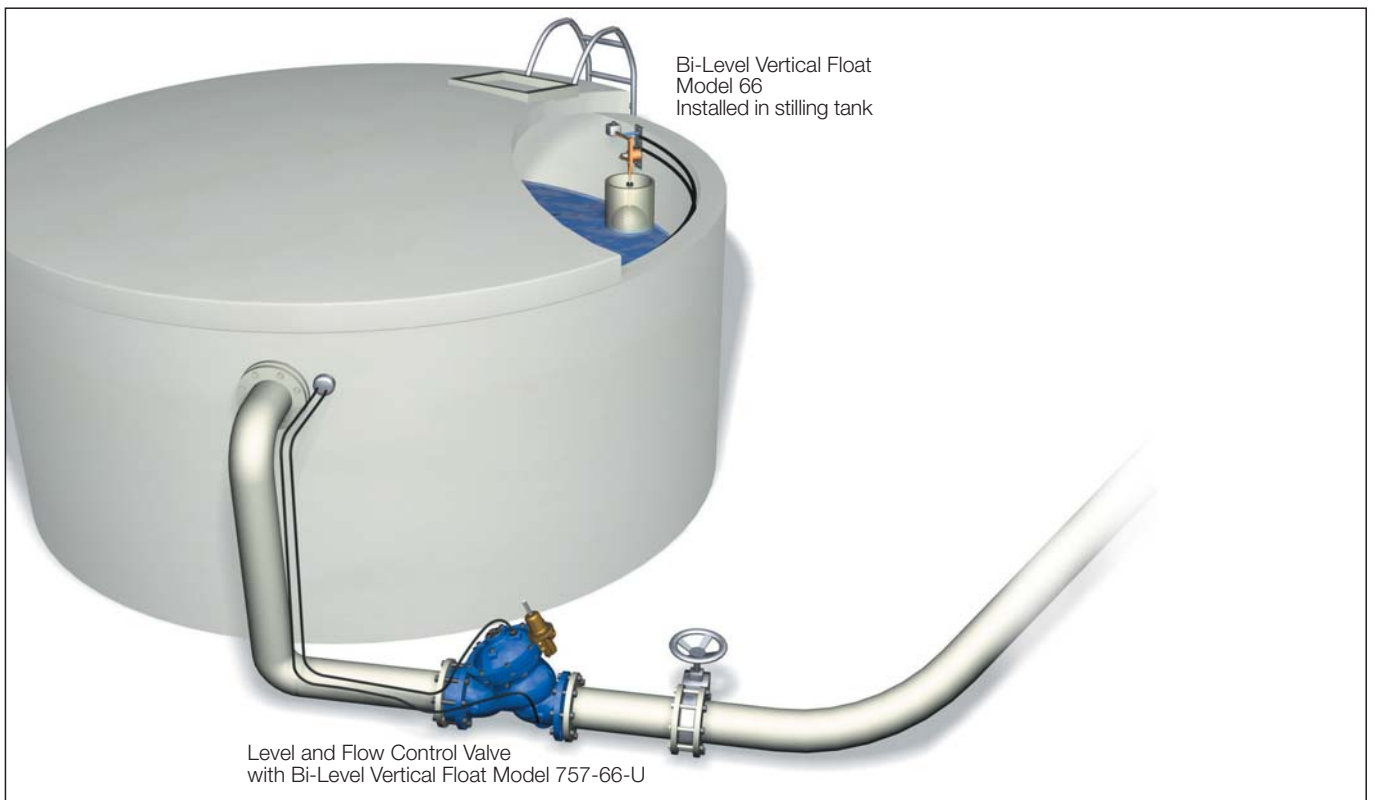

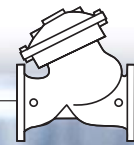

700 Series Model 757-66-U

Technical Data

Dimensions and Weights

Size		A, B		C		L		H		Weight	
mm	inch	mm	inch	mm	inch	mm	inch	mm	inch	kg	lbs
40	1 1/2"	350	14	180	7	205	8.1	239	9.4	9.1	20
50	2"	350	14	180	7	210	8.3	244	9.6	10.6	23
65	2 1/2"	350	14	180	7	222	8.7	257	10.1	13	29
80	3"	370	15	230	9	250	9.8	305	12.0	22	49
100	4"	395	16	275	11	320	12.6	366	14.4	37	82
150	6"	430	17	385	15	415	16.3	492	19.4	75	165
200	8"	475	19	460	18	500	19.7	584	23.0	125	276
250	10"	520	21	580	23	605	23.8	724	28.5	217	478
300	12"	545	22	685	27	725	28.5	840	33.1	370	816
350	14"	545	22	685	27	733	28.9	866	34.1	381	840
400	16"	645	26	965	38	990	39.0	1108	43.6	846	1865
450	18"	645	26	965	38	1000	39.4	1127	44.4	945	2083
500	20"	645	26	965	38	1100	43.3	1167	45.9	962	2121

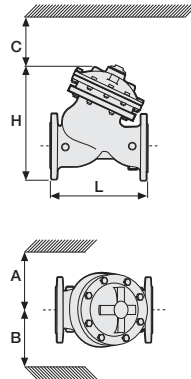

The orifice plate adds 5-12 mm to valves length according to valves size.
Data is for Y-pattern, flanged, PN16 valves
Weight is for PN16 basic valves
"C" enables removing the actuator in one unit
"L", ISO standard lengths available
For more dimensions and weights tables, refer to Engineering Section

Flow Chart

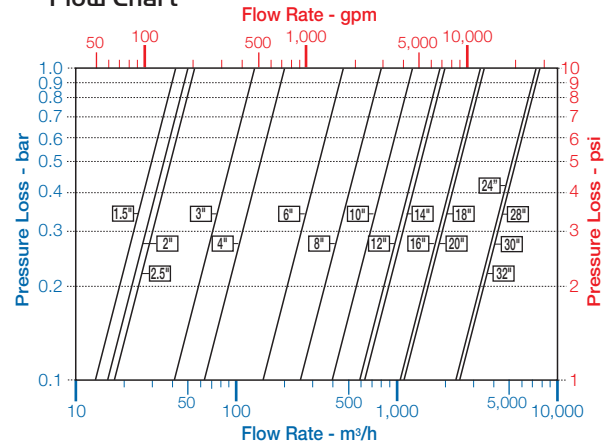

Data is for Y-pattern, flat disk valves
For more flow charts, refer to Engineering Section

Main Valve

Valve Patterns: "Y" (globe) & angle
Size Range: 1 1/2"-32" (40-800 mm)
End Connections (Pressure Ratings):
Flanged: ISO PN16, PN25 (ANSI Class 150, 300)
Threaded: BSP or NPT
Others: Available on request
Working Temperature:
Water up to 80°C (180°F)
Standard Materials:
Body & Actuator: Ductile Iron
Internals:
Stainless Steel, Bronze & coated Steel
Diaphragm:
NBR Nylon fabric-reinforced
Seals: NBR
Coating:
Fusion Bonded Epoxy, RAL 5005 (Blue)
NSF & WRAS approved or Electrostatic Polyester Powder, RAL 6017 (Green)

Control System

Standard Materials:
Accessories:
Bronze, Brass, Stainless Steel & NBR
Tubing: Copper or Stainless Steel
Fittings: Forged Brass or Stainless Steel
Sustaining Pilot Standard Materials:
Body: Brass, Bronze or Stainless Steel
Elastomers: NBR
Springs: Galvanized Steel or Stainless Steel
Internals: Stainless Steel
Float Standard Materials
Pilot body: Brass
Seals: NBR
Internals: Stainless Steel & Brass
Lever system: Brass
Float: Plastic
Float rod: Stainless Steel
Base plate: Fusion bonded epoxy coated Steel
Optional materials: Stainless Steel metal parts and float, FPM (Viton®) seals

Float Assembly Technical Data:

- Minimum level differential: 15 cm (6")
- Maximum level differential: 54 cm (21")
- Each extension rod adds 56 cm (22"), one extension rod supplied
- Extra counterweight required if second extension rod used
- See BERMAD float installation recommendations
- If inlet pressure is below 0.7 bar (10 psi) or above 10 bar (150 psi), consult factory

Orifice Plate:

- O.D. machined according to flange standard
- I.D. machined according to required flow rate

How to Order

Please specify the requested valve in the following sequence: (for more options, refer to Ordering Guide)

Sector	Size	Primary Feature	Additional Feature	Pattern	Body Material	End Connections	Coating	Voltage & Position	Tubing & Fittings	Additional Attributes
WW	6"	757	66	Y	C	16	EB	-	CB	UI
Waterworks	1 1/2" - 32"	Level and Flow Control	Oblique (up to 20") Angle (up to 18") Globe (24-32" only)	Y A G	Epoxy FB Blue Polyester Green Polyester Blue Uncoated	24VAC/50Hz - N.C. 24VAC/50Hz - N.O. 24VDC - N.C. 24VDC - N.O. 24VDC - L.P. 220VAC/50-60Hz N.C. 220VAC/50-60Hz N.O.	EB PG PB UC	Copper Tubing & Brass Fittings Plastic Tubing & Brass Fittings St. St. 316 Tubing & Fittings	CB PB NN	Double Chambered Valve Position Indicator Large Control Filter V-Port Throttling Plug Orifice Assembly Electric Limit Switch St. St. 316 Control Accessories St. St. 316 Internal Trim (Closure & Seat) St. St. 316 Actuator Internal Assembly Delrin Bearing Viton Elastomers for Seals & Diaphragm
		Closing Surge Prevention Modulating Horizontal Float Bi-Level Electric Float Bi-Level Vertical Float Modulating Vertical Float Altitude Pilot Modulating Altitude Pilot Sustaining Altitude Pilot Bi-Level Altitude Control		Ductile Iron Standard Cast Steel St. Steel 316 Nickel Alumin. Bronze	C S N U		4AC 4AO 4DC 4DO 4DP			B I F V U S N T D R E
		2-14 Meter Setting Altitude Pilot 5-22 Meter Setting Altitude Pilot 15-35 Meter Setting Altitude Pilot 25-70 Meter Setting Altitude Pilot	M6 M5 M4 M8	ISO-16 ISO-25 ANSI-150 ANSI-300 JIS-16 JIS-20	16 25 A5 A3 J6 J2		2AC 2AO			

