



Wastewater combination air valve in stainless steel AISI 316 Mod. SCS

The air valve guarantees the proper operation of sewage/industrial lines allowing the entrance of large quantity of air in case of pipe bursting or draining, the release of air pockets during working conditions and the discharge during pipe filling.



Technical features and benefits

- Lower body in AISI 316 designed with strongly sloped walls to avoid grease and/or other material deposit.
- Upper body in AISI 316 containing the air release device in stainless steel, protected against possible projections and spurts during rapid filling phases, by a stainless steel deflector.
- Mobile block including a shaft and a large float, both in stainless steel AISI 316, placed on the lower body and connected to the air release mechanism and to the main orifice obturator.
- Drainage valve for chamber control and draining.
- Maintenance can be easily performed from the top without removing the air valve from the pipe.
- Evacuation bend suitable for flooded environments with 1" threaded outlet.

Applications

- Industrial and civil plants in presence of liquid with solids and debris.
- Mines.
- Desalination plants.
- Deep well boreholes.
- Special version as a gas air release valve.

Operating principle



Discharge of large volumes of air

During the pipe filling it is necessary to discharge air as water flows in. The SCS, thanks to an aerodynamic body and deflector, will make sure to avoid premature closures of the mobile block during this phase.

Air release during working conditions

During operation the air produced by the pipeline is accumulated in the upper part. Little by little it is compressed and its volume increases, pushing the liquid level downwards allowing the air release through the nozzle.

Entrance of large volumes of air

During pipeline draining, or pipe bursts, it is necessary to bring in as much air as the quantity of outflowing water, to avoid negative pressure and serious damages of the pipeline and the entire system.

Optional



■ **Vacuum breaker version Mod. SCS 2F**, to allow the entrance and discharge of large volumes of air only. This model is normally recommended in changes in slope ascending, long ascending segments, and wherever the air release won't be required.



■ **Version for air discharge only SCS EO series (on request)**, available both for SCS and SCS 2F models. The most important application of EO is to allow the air valve installation in those locations of the system where HGL may drop below the pipe profile, and to any other node where for project requirements air entrance must be avoided.

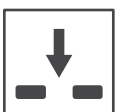

■ **Version for air entrance only SCS IO series**, available for vacuum breaker model only. The most important application of IO is to allow the air valve installation in those locations of the system where, for project requirements, air discharge and release must be avoided.

Technical data

Air flow performance charts

AIR DISCHARGE DURING PIPE FILLING

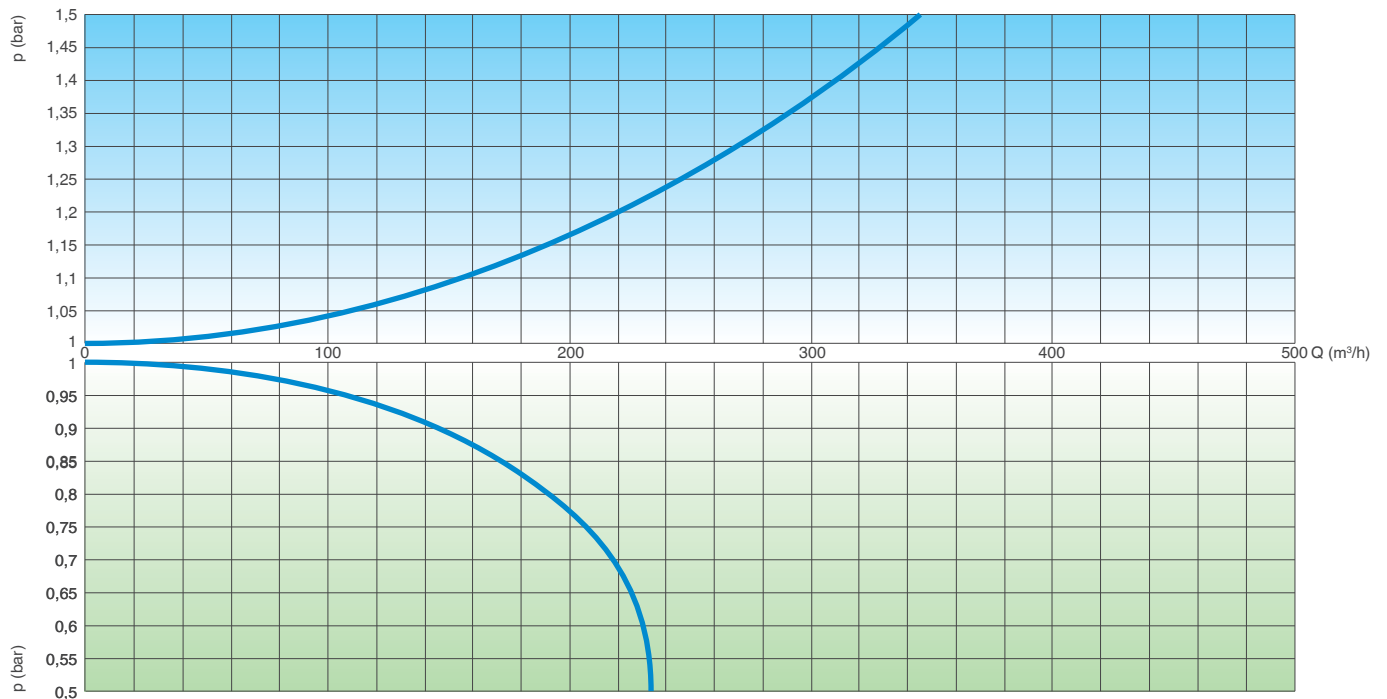

AIR ENTRANCE DURING PIPE DRAINING

The air flow charts were created in Kg/s from laboratory tests and numerical analysis, then converted using a safety factor.

Working conditions

- Waste water max. 70°C.
- Maximum pressure 16 bar.
- Minimum pressure 0,6 bar.
- Version for high temperature available on request.

Standard

- Designed in compliance with EN-1074/4.
- Manufactured with 2" outlet; supplied on request with flanges according to EN 1092/2 or ANSI.
- Changes on the flanges details on request.

Nozzle choice

Nozzle diameter in mm according to the size of the air valve and the PN.

	PN 10	PN 16
DN 2"	2	2

Weight and dimensions

DN (C)	A	B	D	E	Main orifice	Nozzle	Weight
inch	inch	mm	mm	mm	mm ²	mm ²	Kg
2"	1"	415	137	106,5	490	2,3	4

All values are approximate, consult CSA service for more details.

AIR RELEASE DURING WORKING CONDITIONS

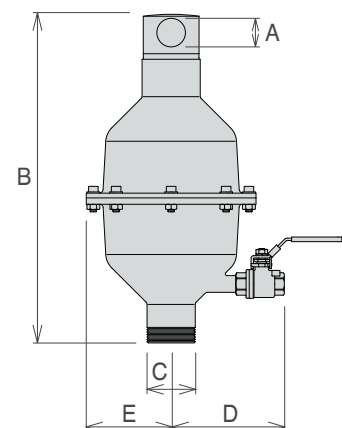
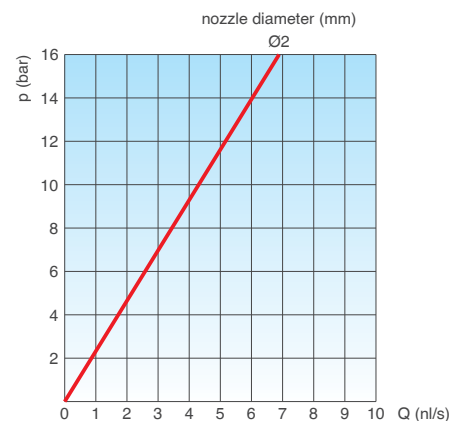

Technical details

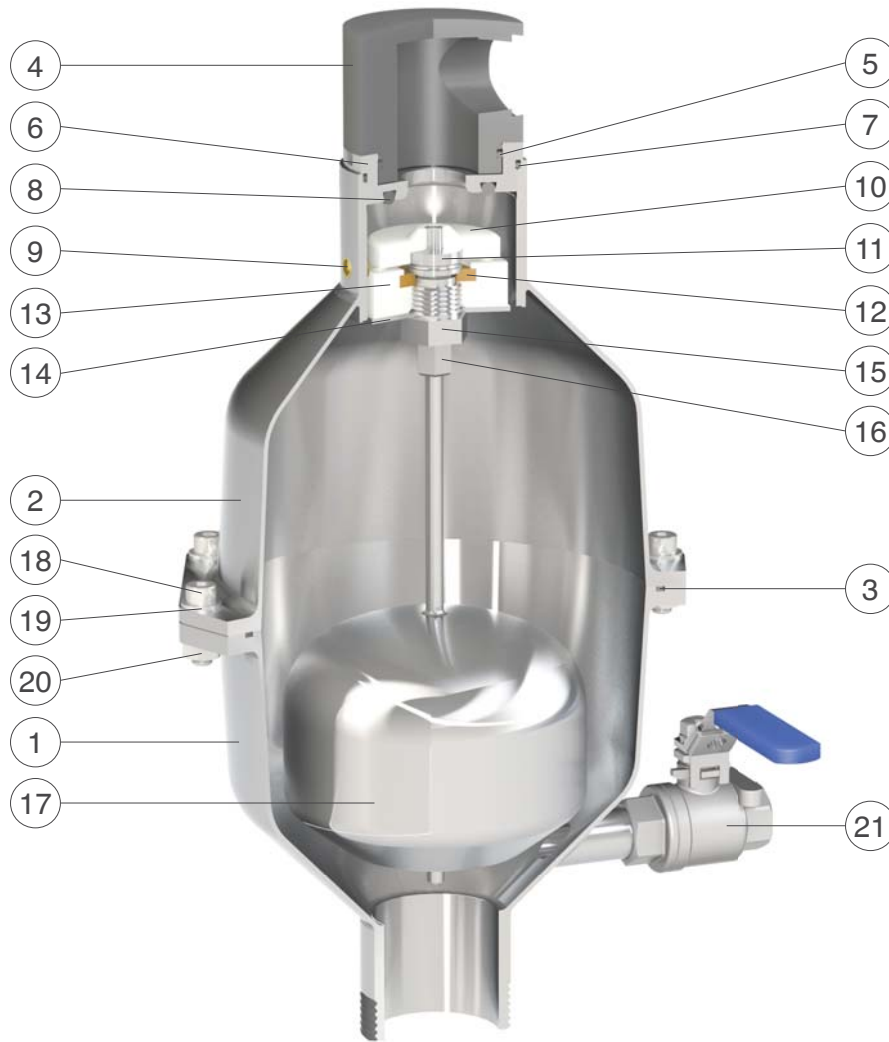

N.	Component	Standard material	Optional
1	Lower body	stainless steel AISI 316	
2	Upper body	stainless steel AISI 316	
3	O-ring	NBR	EPDM/Viton/silicone
4	Cap	PVC	
5	O-ring	NBR	EPDM/Viton/silicone
6	Seat	stainless steel AISI 316	
7	O-ring	NBR	EPDM/Viton/silicone
8	Seat gasket	NBR	EPDM/Viton/silicone
9	Plug	brass OT58	stainless steel AISI 316
10	Obturator	polypropylene	
11	Nozzle subset	stainless steel AISI 316	
12	Plane gasket	NBR	
13	Lower gasket holder	polypropylene	
14	Deflector	stainless steel AISI 316	
15	Guiding nut	stainless steel AISI 316	
16	Upper gasket holder	stainless steel AISI 316	
17	Float	stainless steel AISI 316	
18	Screws	stainless steel AISI 304	stainless steel AISI 316
19	Washers	stainless steel AISI 304	stainless steel AISI 316
20	Nuts	stainless steel AISI 304	stainless steel AISI 316
21	Drain valve	stainless steel AISI 316	

The list of materials and components is subject to changes without notice.