



# Wastewater combination air valve with anti-surge mechanism Mod. SCF - RFP

The SCF-RFP guarantees the proper operation and safety of pressurized sewage systems allowing the release of air pockets in working conditions and the entrance of large quantities of air, in case of pipe bursting or draining phases. The air discharge velocity is maintained within a safety level by means of a anti-surge mechanism to prevent water hammer.



## Technical features and benefits

- Large lower body designed with strongly sloped high walls to avoid deposit of grease or other material, and containing four ribs obtained by casting to guide the stainless steel float.
- Mobile block including a large AISI 316 stainless steel float, placed on the lower body and connected through a stainless steel rod to the air release system.
- Drainage valve for chamber control and draining.
- RFP anti-surge automatism composed of two floats in solid polypropylene, where the upper one will be automatically lifted in case of excessive air outflow, reducing the water approach velocity and avoiding potential water hammer events.
- Nozzle and gasket holder (patent pending) wear resistant thanks to gasket compression control.
- Maintenance can be easily performed from the top without removing the air valve from the pipe.
- Upper body in stainless steel.

## Applications

- Sewage main transmission lines.
- Treatment plants.
- Irrigation systems in presence of solids/debris in suspension.
- Whenever the technology of air valves for treated water can't be used, for the risk of clogging and damages to the internal components, and the proper protection of the system has to be provided.

## Operating principle

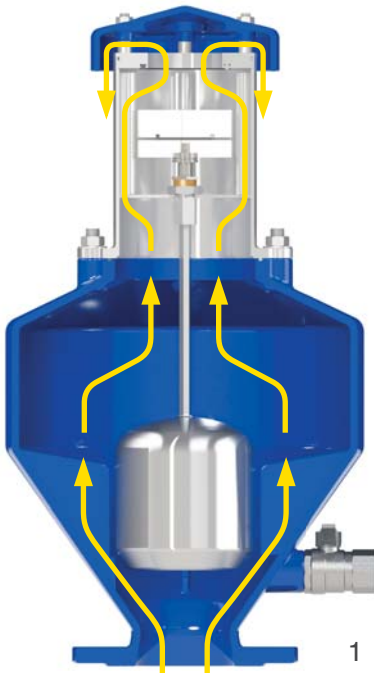

### 1. Discharge of large volumes of air

During the pipe filling it is necessary to discharge air as liquid flows in. The SCF RFP, thanks to a large upper body and an aerodynamic deflector, will make sure to avoid premature closures of the mobile block during this phase.

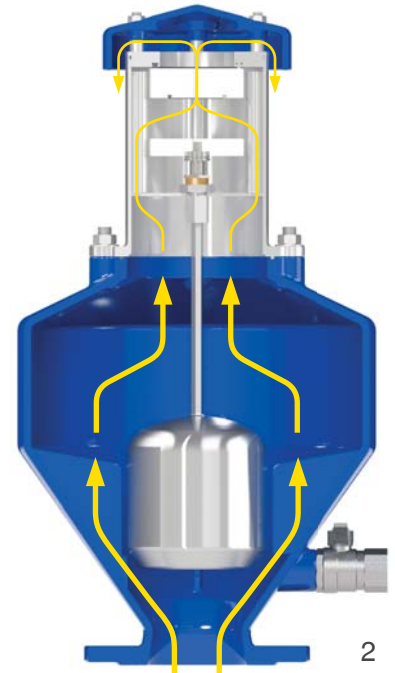

### 2. Controlled outflow

If the differential pressure of air across the valve during pipe filling, and the consequent air outflow, rises above a certain value without control, there is the risk of potential water hammer and damages to the system caused by rapid closures of the mobile block. Should that happen the SCF RFP anti-surge float will rise automatically reducing air outflow and slowing down the velocity of the approaching water column.

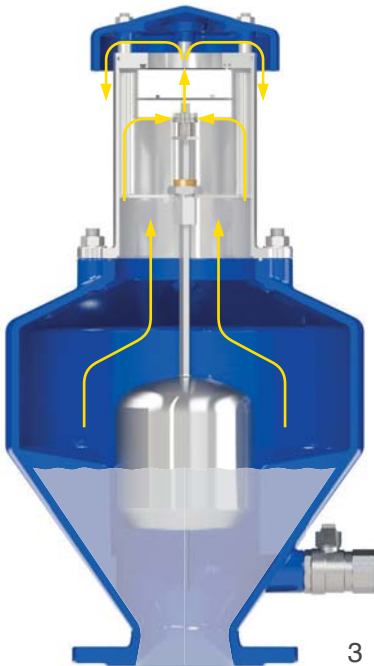

### 3. Air release during working conditions

During operation the air produced by the pipeline is accumulated in the upper part. Little by little it is compressed and its volume increases, pushing the liquid level downwards and allowing the air release through the nozzle.

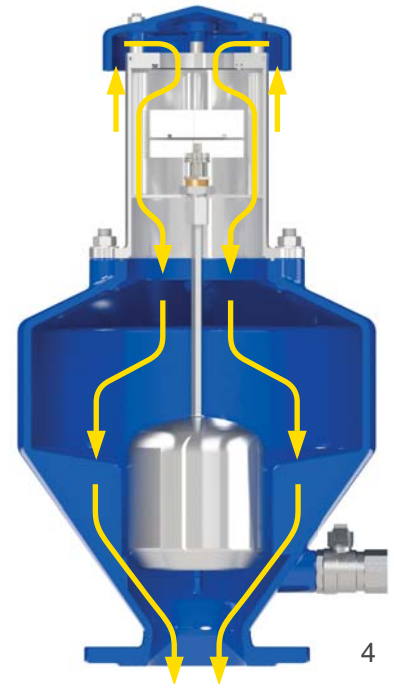

### 4. Entrance of large volumes of air

During pipeline draining, or pipe bursts, it is necessary to bring in as much air as the quantity of outflowing liquid to avoid negative pressure and serious damages to the pipeline, and the entire system.

## Optional



■ **Vacuum breaker version Mod. SCF 2F RFP**, to allow the entrance of large volumes of air only with the controlled air outflow thanks to the RFP technology. This model is normally recommended in changes on slope ascending, long ascending segments, and wherever the air release won't be required.



■ **Version for submerged applications SUB series**, standard for DN 50/80, available both for SCF RFP and SCF 2F RFP Models, with elbow for air conveyance. The design sprang from the necessity of having an air valve performing also in case of flood, without the risk of contaminated water entering the pipeline. Another benefit of SUB is to avoid the spray effect, conveying spurts coming from the rapid closure of the air valve.

## Technical data

### Air flow performance charts

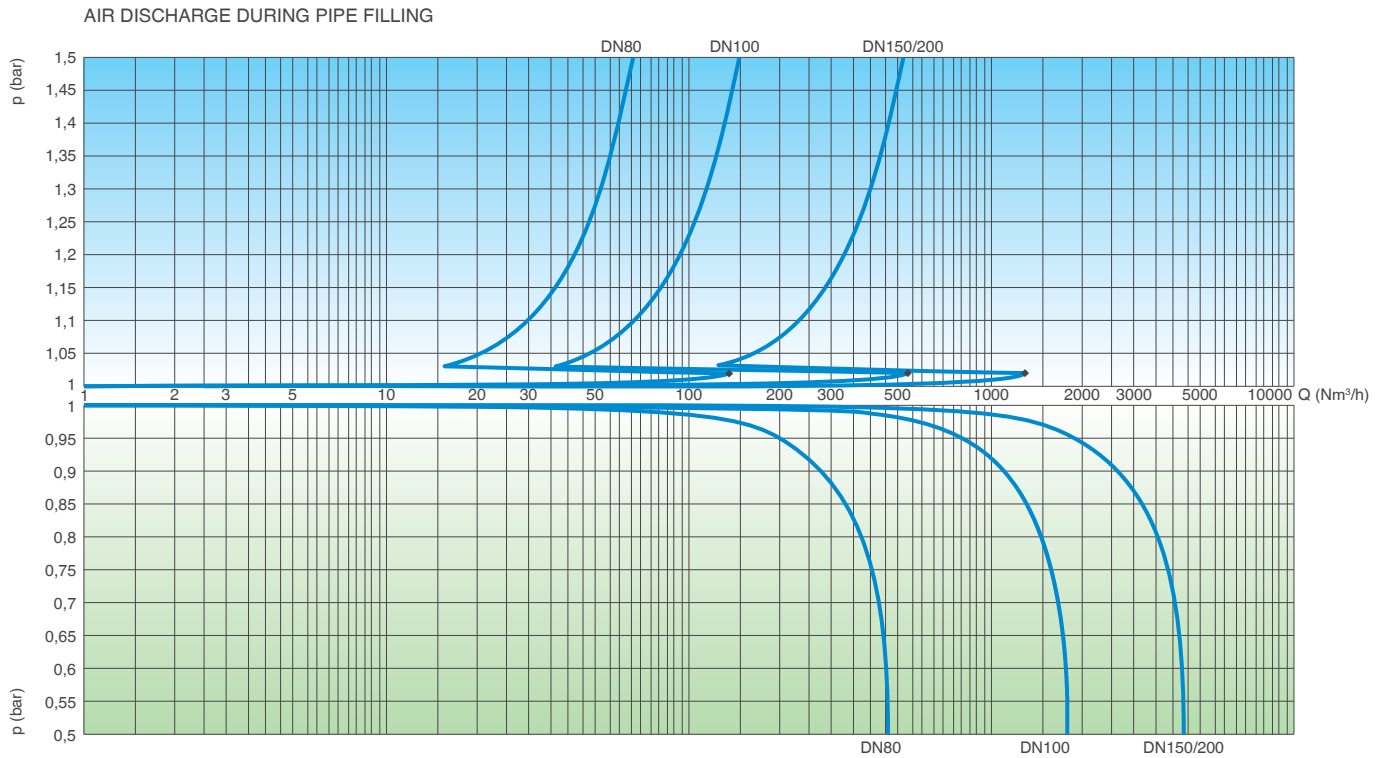

AIR ENTRANCE DURING PIPE DRAINING

The air flow charts were created in Kg/s from laboratory tests and numerical analysis, then converted in Nm<sup>3</sup>/h using a safety factor.

### Working conditions

Pressure rating PN 16:  
0.09 - 16 bar  
Temperature max. 60°C.

Coating FBE - RAL 5005.

### Standard

Designed in compliance with:

- EN-1074/4.

### Surge protection nozzle specification

Diameter and area of the surge protection nozzle (different values on request).

	Ø orifice (mm)	A orifice (mm <sup>2</sup> )
DN 80	10	78,5
DN 100	15	176,5
DN 150/200	28	615,5

### AIR RELEASE DURING WORKING CONDITIONS

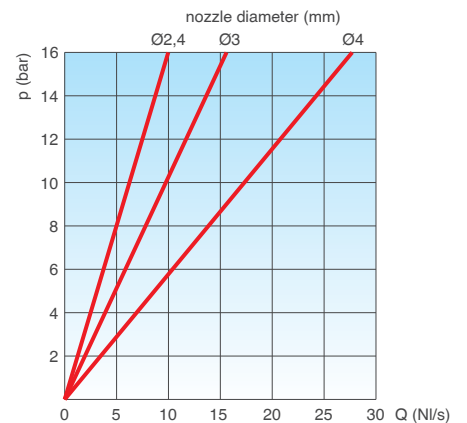

### Connections

Flanges: ■ AS 4087 PN 16  
■ ANSI on request.

### Weights and dimensions

DN mm	A mm	B mm	B' mm	C mm	D mm	Weight Kg
80	185	-	680	300	190	29
100	220	645	-	350	202	40
150	285	870	-	488	243	78
200	340	870	-	488	243	82

All values are approximate, consult CSA service for more details.

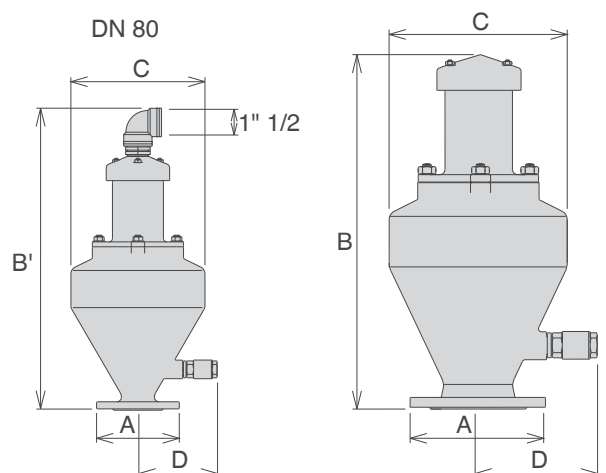

## Technical details

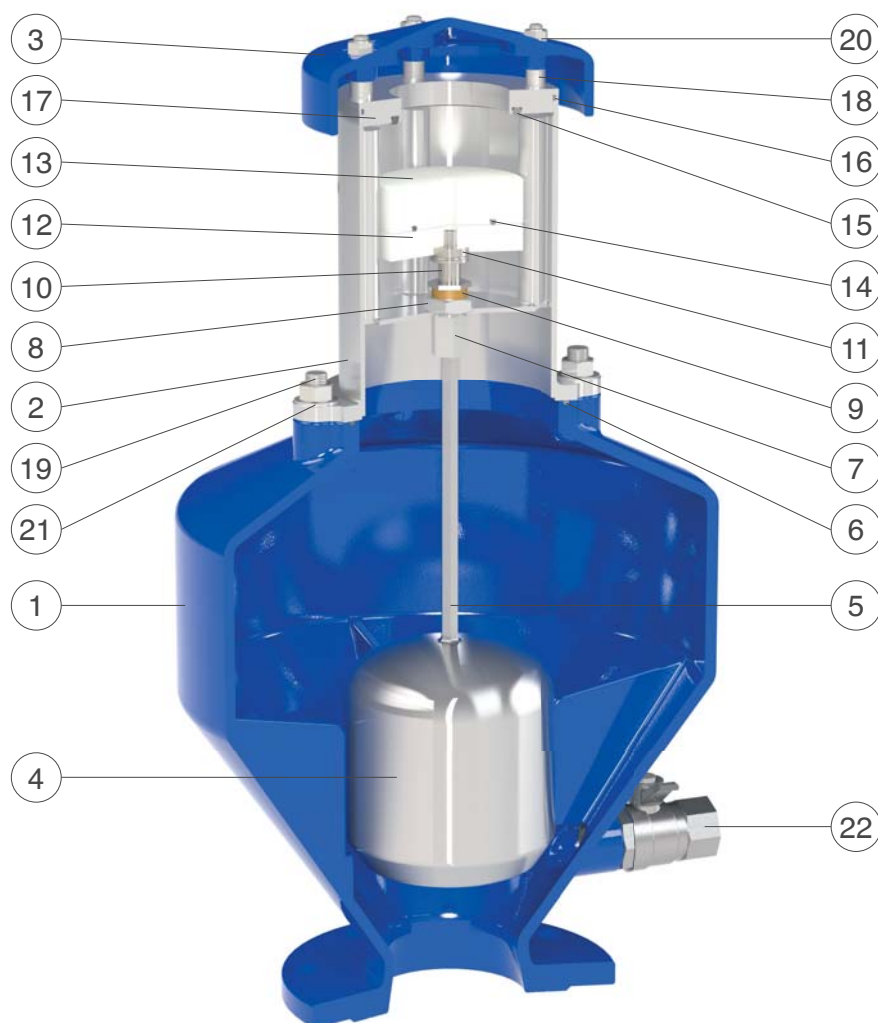

Threaded PP evacuation bend 1" 1/2 supplied as a standard for DN 80.  
The SUB kit is available on request for other sizes.

N.	Component	Standard material	Optional
1	Lower body	ductile cast iron GJS 500-7 or GJS 450-10	
2	RFP upper body	stainless steel AISI 316	
3	Cap	ductile cast iron GJS 500-7 or GJS 450-10	
4	Float	stainless steel AISI 316	
5	Float shaft	stainless steel AISI 316	
6	O-ring	NBR	EPDM/Viton/silicone
7	Driving sleeve	stainless steel AISI 303	stainless steel AISI 316
8	Nut	stainless steel AISI 304	stainless steel AISI 316
9	Plane gasket	NBR	
10	Gasket holder	stainless steel AISI 316	
11	Nozzle subset	stainless steel AISI 316	
12	RFP obturator flat	polypropylene	
13	Anti-surge flat	polypropylene	
14	Anti-surge flat gasket	NBR	EPDM/Viton/silicone
15	Seat gasket	NBR	EPDM/Viton/silicone
16	O-ring	NBR	EPDM/Viton/silicone
17	Seat	stainless steel AISI 316	
18	Spacers	stainless steel AISI 304	
19	Studs	stainless steel AISI 304	stainless steel AISI 316
20	Nuts	stainless steel AISI 304	stainless steel AISI 316
21	Washers	stainless steel AISI 304	stainless steel AISI 316
22	Ball valve 1"	stainless steel AISI 316	

The list of materials and components is subject to changes without notice.