

Kinetic (Air / Vacuum) Air Valve

Model K10



Installation, Operation and
Maintenance Manual (IOM)



Table of Contents

General	Page 2
Safety	Page 2
Operational Data	Page 3
Materials and Connections	Page 3
K10 (1", ¾") Parts List	Page 4
K10 (2") Parts List	Page 5
Unpacking and post shipment inspection	Page 6
Site Preparation	Page 6
Installation.....	Page 7
Start-up and first operation	Page 9
Operation and Maintenance	Page 9
Inspection	Page 10
Troubleshooting	Page 11
Disassembling and Reassembling the valve (1", ¾").....	Page 12
Disassembling and Reassembling the valve (2")	Page 14

General

BERMAD K10 is a high quality Kinetic air valve for a variety of irrigation networks and operating conditions. It evacuates air during pipeline filling and enables large volume air intake in the event of network draining.

With its advanced aerodynamic design and Kinetic orifice, this valve provides excellent protection against vacuum formation with improved sealing at low pressure.

This document is the Installation, Operation and Maintenance manual (IOM) of this valve; it describes the procedures required for proper usage of the valve.

Safety

Since air valves operate in pressurized water networks and sewage systems you are required to carefully read this manual before using the valve. Handle the valve with care and make sure to comply with all the relevant required safety instructions and standards, general and local.

Operational Data

Pressure rating	ISO PN10, ANSI / ASME 150
Operating pressure range	0.1-10 bar / 1.5-150 psi
Operating temperature	Water up to 60°C / 140°F

Materials and Connections

Body material	Glass-reinforced plastic
Inlet diameter	DN20, DN25, DN50 (¾", 1" 2")
Connections	Threaded Male BSPT, NPT for ¾", 1" (DN20, DN25) Threaded Female BSP, NPT for 2" (DN50)
Outlet types	Sideways

K10 1", ¾" Parts List

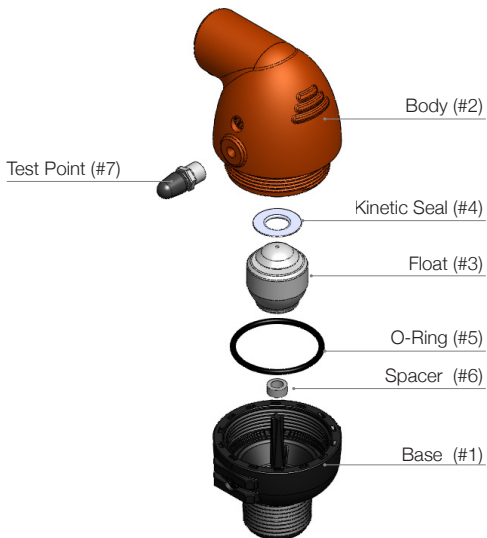

K10 2", Parts List

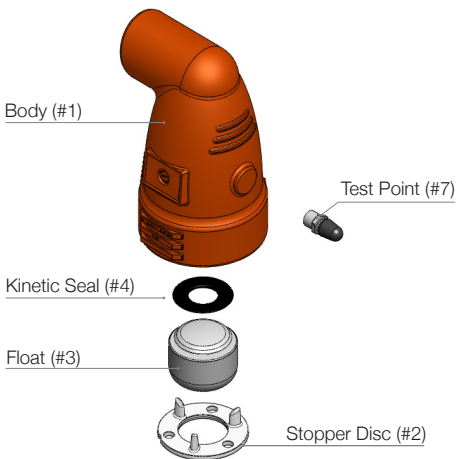

Unpacking and post shipment inspection

- Make sure that till the actual installation the valve remains dry and clean in its original package.
- Unpack the valve and make sure that all the wrapping materials are removed.
- Before installation it is necessary to inspect that no damage to the valve had occurred during shipment; do not install a damaged valve!
- Verify that the valve to be installed meets the design specifications of the specific installation site; take extra care and make sure that the expected system pressure complies with the pressure rating of the valve.

Site Preparation

- Air Valves located above ground should be protected from freezing, contamination and vandalism.
- If the valve is to be installed in a pit, make sure that the pit has proper drainage and sufficient dimensions for servicing the valve.
- Flush the pipeline prior to the Air Valve installation in order to prevent damage to the valve internals due to large debris carried by the water during startup.

- The K10 air valve is not to be used in systems containing high suspended solids; consider selecting other Bermad Air Valve models for such water type.

Installation

Typical Applications

- Main irrigation networks - Air relief and vacuum prevention downstream of pumps, along supply lines and at elevations in main irrigation networks.
- Irrigation control head – Air relief and vacuum prevention at filtration and fertilization stations.
- Infield systems – Prevention of vacuum formation.
- Landscape irrigation – Prevention of vacuum formation.

Installation instructions

- Install the Air Valve as close as possible to the pipe, at a high point of its circumference, in vertical position (within 5 degrees of vertical alignment) and with its inlet facing down.
- The diameter of the pipe connecting the Air Valve with the pipeline should be at least equal to the Air Valve inlet diameter.
- Install a shutoff valve between the air valve and the pipeline for allowing easy inspection and maintenance.

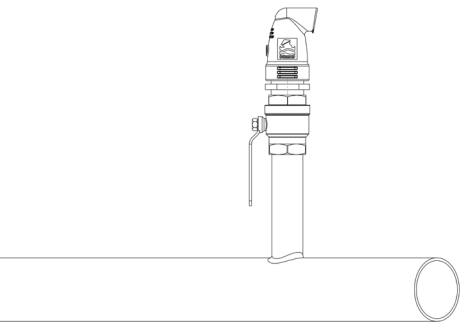

Start-up and first operation

- Open the shutoff valve and verify that the Air Valve connections are not leaking; if needed follow the troubleshooting instruction section of this document. Please note that at the first time the valve is filled up some water may exit through its outlet port.
- Prevent water hammer during startup and pipeline filling; maintain the velocity lower than 0.5m/sec (1.6 feet/sec).

Operation and Maintenance

Principles of Operation

Pipeline Filling

During the filling process of a pipeline, high air flow is forced out through the kinetic orifice of the air valve. Once water enters the valve's chamber, the float buoyed upward causes the kinetic orifice to close. The unique aerodynamic structure of the valve body and float ensures that the float cannot be closed before water reaches the valve.

Pressurized Operation

During pressurized operation of the pipeline the kinetic orifice remains closed.

Pipeline Draining

When a pipeline is drained, a negative differential pressure is created causing atmospheric air to push the float down. The kinetic orifice stays open and air enters the valve chamber, preventing vacuum formation in the pipeline.

Inspection

The valve does not require any specific maintenance, however a periodical inspection of the seals and flushing of the valve are recommended for removing debris and foreign objects. The valve's flushing and cleaning frequency depends on water quality and dirt-load.

Troubleshooting

Symptom	Action
Leakage at the inlet connection	Tighten the valve connection, use thread sealant. Check whether any part/seal is damaged.
Leakage at the valve cover	Tighten the valve's cover ($\frac{3}{4}$ ", 1) Check the orifices area for leaks.
Leakage at the valve's outlet	Flush the valve to remove debris, disassemble and inspect the valve's orifice, float and seal. Remove any foreign objects, check and replace any damaged part.
Valve does not relief air or allow air intake	Verify that the operating pressure does not exceed the valve's rated working pressure. Check and remove foreign objects. Clean the valve's internal parts, replace if necessary. Consult Bermad if the symptom continues.

Disassembling and Reassembling the valve 1", ¾"

Disassembling the K10 ¾", 1" valve

1. Release the valve's body (Part #2) by turning it counterclockwise, un-screw and remove it from the valve's Base (Part #1). Make sure that the valve parts, seated within the cover do not fall out of the cover.
2. Inspect the valve basis O-ring (Part #5) and if necessary replace it with a new one. Make sure that the new O-ring is seated correctly in its designated groove in the valve's basis.
3. Pull the float assembly (Part #3) out of the conduit pin and remove it out of the valve-cover.
4. Inspect the float's Kinetic Seal (Part #4) and the float (Part #3) for wear and tear. If necessary replace the old parts.
5. Replacing the Kinetic Seal:
 - a. Remove the old Seal
 - b. Wet the new Kinetic Seal (Part #4) with clean water
 - c. Install the kinetic seal (Part #4) on the Float (Part #3) with its raised edges side facing upward. See Fig. A

Reassembling the K10 3/4", 1" valve

1. Insert the float with the Kinetic Seal on the conduit pin to its place within the valve-cover; make sure that the float freely falls downwards along the conduit pin.
2. Make sure that the valve's basis O-ring (Part #5) is fully inserted to its groove within the basis.
See Fig. B
3. Put the Spacer and the Float on the shaft located in the center of the base.
Make sure that the Float is located in the lower part
See Fig. C
4. Reassemble the valve body to the valve basis by screwing it on the basis thread. Tighten the cover.
5. The valve is reassembled, perform a complete start up procedure as described above.

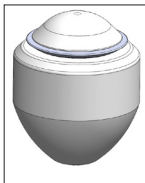

Fig. A

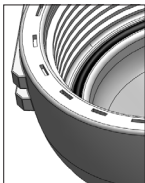

Fig. B

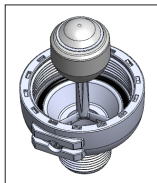

Fig. C

Disassembling and Reassembling the valve K10-2"

Disassembling the K10 2" valve

1. Pull the Stopper Disc (Part #2) out of the valve-cover then pull out the float assembly (Part #3).
2. Inspect the float's Kinetic Seal (Part #4) and the Float (Part #3) for wear and tear. If necessary replace the old parts.
3. Replacing the Kinetic Seal:
 - a. Remove the old seal
 - b. Wet the new Kinetic Seal (Part #4) with clean water
 - c. Install the Kinetic Seal (Part #4) on the Float (Part #3) with its raised edges side facing upward.
See Fig. M

Reassembling the K10 2" valve

1. Insert the float with the Kinetic Seal to its place within the valve-cover while the float-bore facing downward.
See Fig. N
2. Insert the Stopper Disc (Part #2) to its place in the valve-cover with the snap legs facing the float. Use the special locking tool to push the Stopper Disc to its place.
See Fig. P
3. The valve is reassembled, perform a complete start up procedure as described above.



Fig. M

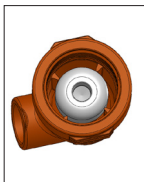
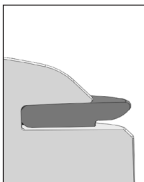

Fig. N

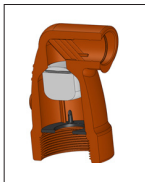
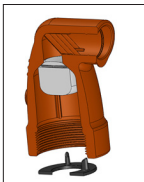
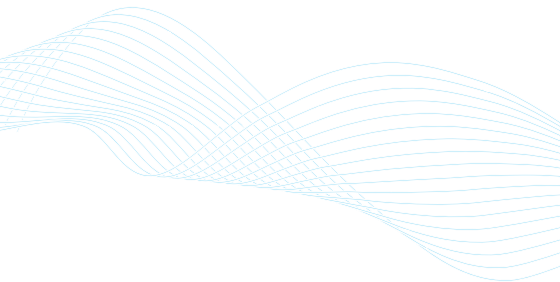

Fig. P





info@bermad.com • www.bermad.com

The information herein is subject to change without notice. BERMAD shall not be held liable for any errors. All rights reserved. © Copyright by BERMAD.

PIAXE12-K10