

Pressure Relief/Sustaining Valve with Solenoid Control

(Sizes 1½-14"; DN40-350)

Description

The Model 730-55 Pressure Relief/Sustaining Valve with Solenoid Control is a hydraulically operated, diaphragm actuated control valve that can fulfill either of two separate functions:

- When installed in-line, it sustains minimum pre-set, upstream (back) pressure regardless of fluctuating demand or varying downstream pressure.
- When installed as a circulation valve, it relieves excessive line-pressure that is above maximum pre-set.

The valve opens and shuts-off in response to an electric signal.

Installation

1. Ensure enough space around the valve assembly for future maintenance and adjustments.
2. Prior to valve installation, flush the pipeline to insure flow of clean fluid through the valve.
3. For future maintenance, install Isolation gate valves upstream and downstream from Bermad control valve.
4. Install the valve in the pipeline with the valve flow direction arrow in the actual flow direction. Use the lifting ring provided on the main valve cover for installing the valve.
5. For best performance, it is recommended to install the valve horizontally and upright. For different valve positions – consult Bermad.
6. After installation carefully inspect/correct any damaged accessories, piping, tubing, or fittings.
7. Cross-Check solenoid specifications with design requirements and solenoid/coil label.
8. Pull and connect a 3-wired cable (per each solenoid), from the control panel to the valve, for the solenoid actuation. Ensure approved cable protection. Confirm that the wires data meet solenoid specifications.
Note: Energizing the solenoid coil when it is not fixed in its place, is dangerous and might burn the coil.
9. Install a pressure gauge (instead of the plastic plug on the pilot)
10. It is recommended to install a strainer Bermad model 70F upstream from the 730-55, to prevent debris from damaging valve operation.

Commissioning & Calibration

1. Confirm that cock valves [1], [2] & [3] are open (handle parallel to cock-valve body).
2. Allow the valve to open by using the solenoid manual override or by: Energizing the solenoid for a Normally Closed Valve, De-Energizing it for a Normally Open Valve & Latching it for a Last Position Valve.
3. Open fully the upstream isolating valve and partially the downstream isolating valve, to fill-up, in a slow and controlled manner, the consumers line downstream from the pressure sustaining valve.
Note: When upstream pressure is below the 730 setting, the valve is closed.
4. Confirm that the supply pressure and the flow through the system are typical.
5. Vent air from the valve's control loop by loosening cover tube fitting at the highest point, allowing all air to bleed. Retighten the tube fitting eyebolt.
6. The Model 730-55 is factory set according to design definitions. The set pressure is marked on the pilot's label. To change the 730-55 setting, follow the steps described below:
 - 6.1. 730-55 @ In-Line Installation:
 - 6.1.1. Close the upstream isolating valve to reduce 730-55 inlet pressure. Ensure that the 730-55 sustains the upstream pressure, preventing it from decreasing below setting, even when the upstream isolating valve is almost closed.
 - 6.1.2. Unlock the pilot locking nut and slowly turn the pilot adjusting screw Clock-Wise to increase set pressure and Counter-Clock-Wise to decrease it.
 - 6.1.3. After the pressure is stabilized, lock the pilot locking nut and open fully the upstream isolating valve.
 - 6.2. 730-55 @ Off-Line (Circulation) Installation:
 - 6.2.1. Confirm that the line pressure is the designed dynamic operating pressure.
Note: When setting is below the designed dynamic operating pressure, the valve is partially/fully open.
 - 6.2.2. Unlock pilot locking nut & slowly turn the adjusting screw Clock-Wise until the valve close & seal.
 - 6.2.3. Slowly turn the pilot adjusting screw Counter-Clock-Wise until the valve starts leaking, re-tighten the setting screw until the 730-55 seals again plus 1/4 – 1/2 turn and lock the locking nut
7. Check solenoid control feature by De-Energizing & Energizing the solenoid to close & open the valve.
8. The Restriction [31] enables the 2-Way control & reduces valve closing speed.

Control Drawing

PARTS LIST

1	2W Cock Valve
2	2W Cock Valve
3	2W Cock Valve
4	Control Filter
31	Restriction Orifice
#3PB-R	2W PB PS Pilot R Sensing
S20	2W NC Solenoid

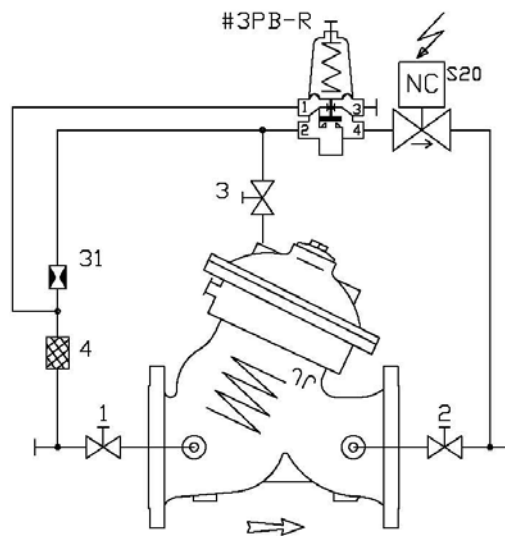

Trouble-Shooting

- Valve fails to Open:** Check for sufficient inlet pressure, create demand/flow, confirm pilot setting & check cock valves status, confirm power supply to solenoid & confirm solenoid coil is not burned (N.C. valves).
- Valve fails to Close:** Create demand/flow, confirm pilot setting, check needle & cock valves status, clean control filter & detect for clogged ports or fittings, confirm power supply to solenoid & confirm solenoid coil is not burned (N.O. valves), check if any debris trapped in the main valve, confirm diaphragm is not leaking.
- Valve fails to Regulate:** Check needle valves setting, release air trapped in the control chamber & check cock valves status.

Preventative Maintenance

- System operating conditions that effect on the valve should be checked periodically to determent the required preventative maintenance schedule.
- Maintenance instructions:
 - Tools required:
 - Metric and imperial wrenches
 - Anti seize grease
 - Visual inspection to locate leaks and external damages
 - Functional inspection including: closing, opening and regulation.
 - Close upstream and downstream isolating valves (and external operating pressure when used).
 - Once the valve is fully isolated vent pressure by loosening a plug or a fitting.
 - Open the stud nuts and remove the actuator as one unit from the valve body. Disassemble necessary control tubs and wires.
 - It is highly recommended to stock a reserve solenoid and an actuator assembly for each size. This allows minimum system field work and system down time.
 - Disassemble the actuator and examine its parts carefully for signs of wear, corrosion, or any other abnormal conditions.
 - Replace worn parts and all the Elastomers. Lubricate the bolts and studs threads with Anti seize grease.

Spare parts

Bermad has a convenient and easy to use ordering guide for valve spare-parts and control system components. For solenoid valves refer to model and S/N on solenoid tags.

Pub # : IOMEW730-55

By: YE 1/08

Rev: 01YE-1/08

File name: IOMEW730-55_01_08

appliceng@bermad.com • www.bermad.com

The information contained in this document is subject to change without notice.

BERMAD shall not be liable for any errors contained herein. All Rights Reserved. © Copyright by BERMAD Control Valves.