

Pressure Reducing Valve with Electronic Multi-level Setting Type 4T

(Sizes 1½-14"; DN40-350)

Description

The Model 720-4T Pressure Reducing Valve with Electronic Multi-level Setting is a hydraulically operated, diaphragm actuated control valve that reduces higher upstream pressure to lower downstream pressure regardless of fluctuating demand or varying upstream pressure. A unique Multi-Setting Pneumatic Controlled (MSPC) unit integrated on the pilot, responds to a Modulo-One controller changing the pilot's set point.

Installation

1. Ensure enough space around the valve assembly for future maintenance and adjustments.
2. Prior to valve installation, flush the pipeline to insure flow of clean fluid through the valve
3. For future maintenance, install Isolation gate valves upstream and downstream from Bermad control valve.
4. Install the valve in the pipeline with the valve flow direction arrow in the actual flow direction. Use the lifting ring provided on the main valve cover for installing the valve.
5. For best performance, it is recommended to install the valve horizontally and upright. For different valve positions – consult Bermad.
6. After installation carefully inspect/correct any damaged accessories, piping, tubing, or fittings.
7. Install a pressure gauge (instead of the plastic plug on the pilot)
8. It is highly recommended to install a strainer Bermad model 70F upstream from the pressure reducing valve to prevent debris from damaging valve operation.
9. Install a pressure relief valve Bermad model 73Q, downstream from the 720-4T, for protection against momentary pressure peaks.
10. Install the **Modulo-One Electronic Pressure Controller** near the valve and connect it according to the **Controller User Guide for Time and/or Flow Operating Modes**.

Commissioning & Calibration

1. Start the calibration procedure with the pneumatic control tube, from the Modulo One to the pilot , disconnected.
2. Confirm that cock valves [1], [2] & [3] are open (handle parallel to cock-valve body).
3. Open fully the upstream isolating valve and partially the downstream isolating valve, to fill-up, in a slow and controlled manner, the consumers line downstream from the pressure reducing system.
4. Confirm that the supply pressure and the flow through the system are typical. If necessary, create flow by opening a hydrant, or reduce the flow/pressure by adjusting the downstream/upstream isolating valves.
5. Vent air from the valve's control loop by loosening cover tube fitting at the highest point, allowing all air to bleed. Retighten the tube fitting eyebolt.
6. The Model 720-4T is factory set according to the design high pressure request. The set pressure is marked on the pilot's label. Allow the pressure that appears in the downstream pressure gauge to stabilize, meeting the marked set pressure.
7. If the set pressure is either different from the design or the requirements have been changed, unlock the pilots locking nut and slowly turn the pilot adjusting screw Clock-Wise to increase set pressure and Counter -Clock-Wise to decrease it. Allow the 720-4T to react and the pressure to stabilize.
8. After the pressure is stabilized, lock the pilots locking nut and open fully the downstream isolating valve.
9. The restriction [31] enables the 2-Way control & reduces valve closing speed.
10. The one way flow control [19] is factory set fully open. To decrease opening speed or to stabilize the valve reaction, turn the needle valve CW.
11. Connect the pneumatic control tube from the Modulo One to the pilot and refer to **Modulo-One Electronic Pressure Controller User Guide for Time and Flow Operating modes**.
12. Calibrating Pressure Reducing Systems that include parallel By-Pass PR Valves, require calibrating each of the PR Valves separately, while the parallel PR Valve/s is closed. Calibration should refer to a shared pressure gauge, installed downstream from the system. For best & long term performance, set larger PRV to 0.5 bar lower than smaller PRV.
13. Relief Valves should be set 1 bar above system highest set-pressure.

Control Drawing

PARTS LIST

1	2W Cock Valve
2	2W Cock Valve
3	2W Cock Valve
4	Control Filter
31	Restriction Orifice
19	One Way Flow Control MT Type
#2PB-4T	2W PB PR Air Compensated Pilot

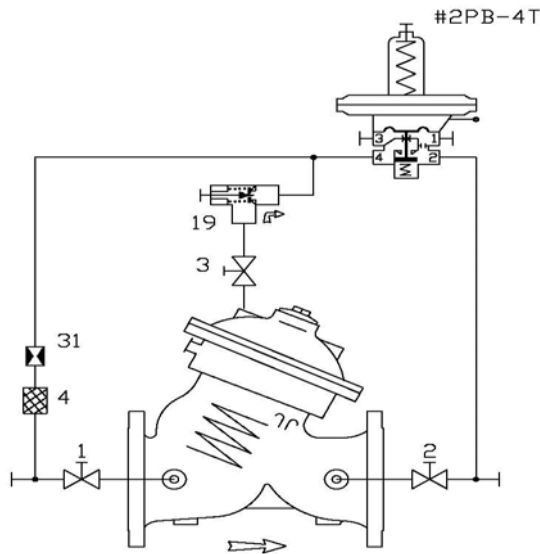

Trouble-Shooting

1. **Valve fails to Open:** Check for sufficient inlet pressure, create demand/flow, confirm pilot setting, check cock & needle valves status.
2. **Valve fails to Close:** Create demand/flow, confirm pilot setting, check needle & cock valves status, clean control filter & detect for clogged ports or fittings, check if any debris trapped in the main valve, confirm diaphragm is not leaking.
3. **Valve fails to Regulate:** Check needle valves setting, release air trapped in the control chamber, confirm controller & sensors functioning, check cock & needle valves status.

See also **Modulo Electronic Pressure Controller User Guide for Time and Flow Operating modes**

Preventative Maintenance

1. System operating conditions that effect on the valve, should be checked periodically to determent the required preventative maintenance schedule.
2. Maintenance instructions:
 - 2.1. Tools required:
 - 2.1.1. Metric and imperial wrenches
 - 2.1.2. Anti seize grease
 - 2.2. Visual inspection to locate leaks and external damages
 - 2.3. Functional inspection including: closing, opening and regulation.
 - 2.4. Close upstream and downstream isolating valves (and external operating pressure when used).
 - 2.5. Once the valve is fully isolated vent pressure by loosening a plug or a fitting.
 - 2.6. Open the stud nuts and remove the actuator as one unit from the valve body. Disassemble necessary control tubs.
 - 2.7. It is highly recommended to stock a reserve actuator assembly for each size. This allows minimum system field work and system down time.
 - 2.8. Disassemble the actuator and examine its parts carefully for signs of wear, corrosion, or any other abnormal conditions.
 - 2.9. Replace worn parts and all the Elastomers. Lubricate the bolts and studs threads with Anti seize grease.

Spare parts

Bermad has a convenient and easy to use ordering guide for valve spare-parts and control system components. For solenoid valves refer to model and S/N on solenoid tags.

Pub # : IOMEW720-4T	By: YE 1/08	Rev: 01YE-1/08	File name: IOMEW720-4T_01_08
---------------------	-------------	----------------	------------------------------

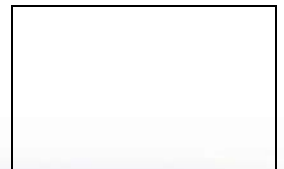

appliceng@bermad.com • www.bermad.com

The information contained in this document is subject to change without notice.

BERMAD shall not be liable for any errors contained herein. All Rights Reserved. © Copyright by BERMAD Control Valves.

