



CSA products for industry/seawater

**Anti-slam  
combination air valve**

Mod. GOLIA 3F-AS

---

### Instructions

These instructions provide installation, operation and maintenance information for CSA Mod. GOLIA 3F AS combination air valves. They are for use by personnel who are responsible for installation, operation and maintenance of CSA Air/Vacuum release valves.

### Safety Messages

All safety messages in the instructions are flagged with an exclamation symbol and the word Caution, Warning or Danger. These messages indicate procedures that must be followed exactly to avoid equipment damage, personal injury or death. If a safety sign or symbol becomes difficult to see or read, please contact CSA.

 <b>WARNING!</b>  <b>Personnel involved in the installation or maintenance of valves should be constantly alert to potential emission of pipeline material and take appropriate safety precautions. Always wear suitable protection when dealing with hazardous pipeline materials. Handle valves, which have been removed from service, with suitable protection for any potential pipeline material in the valve.</b>
--

### Inspection

Your CSA GOLIA 3F-AS combination air Valve has been packaged to provide protection during shipment; however, it can be damaged in transport. Carefully inspect the unit for damage upon arrival and file a claim with the carrier if damage is apparent.

### Parts

Recommended spare parts are listed on the assembly drawing. These parts should be stocked to minimize downtime. Order parts from your local CSA sales representative if available, or directly from CSA. When ordering parts, please include the model, type and numbers located on the data plate placed on the valve. Also include the part name, the assembly drawing number, and the quantity stated on the assembly drawing.

### CSA Service

CSA service personnel are available to maintain and repair all CSA products. CSA also offers customized training programs and consultation services.

For more information, contact your local CSA sales representative if available, or directly CSA. Visit our website at [www.csasrl.it](http://www.csasrl.it).

## Table of Contents

Description - - - - -	4
Handling and Storage - - - - -	4
Installation - - - - -	4
Maintenance - - - - -	5
Drawings - - - - -	7
Troubleshooting - - - - -	8
Guarantee - - - - -	9

### Description

The CSA GOLIA 3F-AS combination air valve is designed perform under the following applications:

- to release air pockets in working conditions;
- to allow the entrance or large volumes of air during pipe draining, or burst operations;
- to control the air outflow avoiding water hammer caused by sudden closure of the float due to rapid pipeline filling and transients events. Please make reference to the technical data sheets and animations available for a better understanding of the operating principle, or contact CSA for further support.

This type of air valve should not be considered as a pressure relief for shock conditions and water hammer events, developing elsewhere in the system, for which other and different CSA models and solutions are available.

The maximum and minimum pressure are stated in the order and according to technical literature. In general we recommend to ensure at least 0,3 bar acting on the air valve to ensure the perfect sealing during working conditions.

### Handling and Storage

Lifting the valve improperly may damage it. Lift the valve with slings, chains or cables fastened around the valve body, eyebolts if present or using the studs already threaded to the flanges.

If installation will be delayed, place valve indoors in secure, weather tight storage. If temporary outside storage is unavoidable, make sure a vermin proof rain cover is secured around/over the valve to keep off rain and mud. Skid and set the assembly on a flat, solid, and well drained surface for protection from ground moisture, runoff and pooled rain water. Do not leave the valve exposed to high humidity and excessive temperature conditions.

### Installation

The anti-slam combination air valve should always be installed in a vertical position. An isolation valve between this unit and the transmission (pipeline) system is necessary to allow maintenance and valve's inspection. Where to use:

- high points in pipelines where the hydraulic gradient and flow conditions are such that a negative pressure can possibly occur;
- change in slope descending and ascending (for the latter air vacuum models are normally enough);
- downstream of sectioning devices in a pipeline such as a check, gate valves, butterfly valves where vacuum can occur upon closure;
- downstream of pumps to prevent water hammer in case of power failure in presence of negative pressure conditions;
- anywhere on the system where column separation is likely to occur.

**Note to Engineer:** If the air valve is to be installed inside a pump house, near control panels, in a building, use threaded or flanged connections (to be supplied on request) and pipe back into the well or to outside obtained by CSA SUB kit. This will greatly muffle the high noise level caused by the air being discharged , and provide for drainage of any small amount of water or water vapour that may accumulate.

Same thing applies in case of possible flooding of the installation chamber to avoid the entrance of polluted water.

- Before installation, remove foreign material such as weld spatter, oil, grease, and dirt from the pipeline.
- Prepare pipe ends and install valves in accordance with the pipe manufacturer's instructions for the joint used.
- Tighten the flange bolts or studs in a crisscross pattern and minimum of four stages.

## Maintenance

The anti-water hammer combination air valve Golia 3F-AS is automatic in operation and requires very little maintenance. It should always be installed in a vertical position with a maximum tilt within 3°. The anti-slam systems is never in contact with fluid and therefore not subject to servicing.

A semi-annual visual inspection for leakage and AS spring compression is recommended.

A malfunction of the air valve can be identified by the seepage of water through the air release nozzle and/or through the main seat. Should a malfunction occur, the following steps should be taken to repair the valve;

### *Disassembly procedure*

See Figures 1 on page 7 for part identification.

1. Relieve pipeline pressure or shut off isolation valve before servicing the Air Valve.



#### **WARNING!**

**Servicing the Air/Vacuum Valve while the pipeline is under pressure can cause personal injury or equipment damage. Relieve pipeline pressure or shut off isolation valve before servicing the Air/Vacuum Valve.**

2. Slowly open the drain port (12) to relieve internal pressure



#### **WARNING!**

**Do not completely remove pipe plug or cover screws while the valve is under pressure.**

3. Remove cover nuts (25) and cover (2).
4. Remove the strainer (15)



#### **WARNING!**

**When removing the strainer be aware of sharp edges, use protective gloves and exert care during handling**

5. Remove the seat nuts (10) and extract the seat (5) along with AS mechanism with it (the latter composed of the spring guide (16), spring (17), shaft (18), screw (26), AS flat (21) with adjustable holes for the controlled air outflow. Pay attention not to damage the o-rings 24, 4 and 3.
6. Do not try to pull apart/disassemble the AS mechanism without the support of CSA personnel.
7. Inspect sealing surface of the seat and check whether gaskets 3, 4 are torn or damaged.
8. Pull out the mobile block composed of the upper float (7) and lower float (8) joined together by the air release system (6).
9. Inspect the o-ring (24) making sure it is not torn or damaged
10. Inspect the air release system (6) , clean it with some water and replace it if needed
11. Do not try to pull apart the air release system (6) without the support of CSA personnel
12. Inspect all connections of linkage for excessive wear.
13. Clean all surfaces before re-assembly.
14. Do not remove the body unless strictly necessary, in such case after removing it inspect the o-ring (23) paying attention to locate it properly back to the groove during reassembly
15. Check to see if foreign matter or dirt is preventing float (8) from seating properly on the air deflector/diffuser (11).
16. Clean as necessary.

### *AS spring compression control*

When doing the spring compression control, recommended every 6 months, proceed according to the disassembly procedure until point 4. Once the strainer has been removed, by exerting a small pressure on top of the AS spring guide nut (16) you should be able to push down the shaft (18) connected to the AS flat (21) opening the passage through the main seat (5). For excessive friction, contact CSA for an immediate assistance.

## Drawings

Figure 1: GOLIA 3F-AS

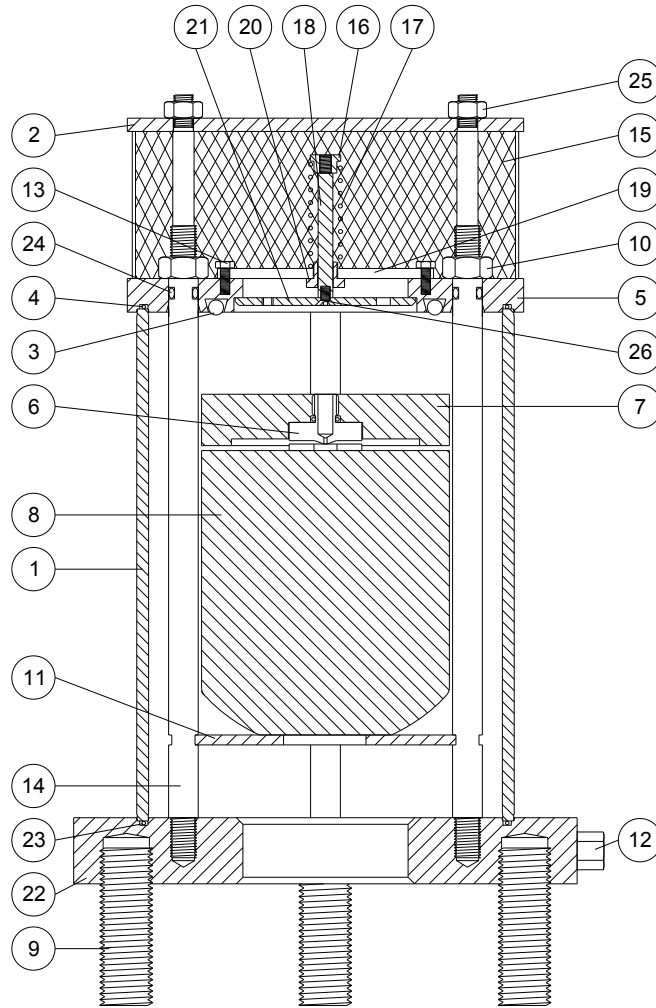

N.	Component	Material
1	Body	AISI 316/Duplex/Super Duplex
2	Cap	AISI 304/AISI 316
3	O-ring	NBR/EPDM/Viton/silicone
4	O-ring	NBR/EPDM/Viton/silicone
5	Seat	AISI 316/Duplex/Super Duplex
6	Nozzle subset	AISI 316/Duplex
7	Upper flat	PP
8	Float	PP
9	Studs	AISI 304/AISI 316
10	Nuts	AISI 316
11	Diffuser	AISI 316/Duplex/Super Duplex
12	Drain valve	AISI 316
13	Screws (from DN 150R)	AISI 316
14	Spacers	AISI 316/Duplex/Super Duplex
15	Filter	AISI 304/AISI 316
16	Spring guide nut (from DN 100)	AISI 303/AISI 316
17	Spring	AISI 302
18	AS shaft	AISI 303/AISI 316
19	Spring support (from DN 150R)	AISI 304/AISI 316
20	Guiding nut (from DN 150R)	Delrin (polyoxymethylene)
21	AS flat	AISI 316
22	Flange	AISI 316/Duplex/Super Duplex
23	O-ring	NBR/EPDM/Viton/silicone
24	O-ring	NBR/EPDM/Viton/silicone
25	Nuts	AISI 316
26	Screw	AISI 316

Spare parts: 3-4-6-7-8-23-24

## Troubleshooting (ref. picture 1 on page 7)

Condition	Possible Cause	Corrective Action
Valve leaks at flange joint.	Loose flange bolting.	Tighten flange bolting.
	Blown flange gasket.	Replace flange gasket.
	Miss-alignment or damage to field piping and supports.	Adjust miss-alignment or repair piping or supports.
	Damaged flange face/s or improper flange connections.	Repair flange, replace valve body or adjust flange connections.
Valve leaks out of the main sealing seat (5).	Valve is not vertical	Place the valve in a vertical position (max 3° tilt angle)
	Possible corrosion through the body and seat	Check the fluid chemicals parameters and contact CSA
	Dirt accumulation on the seat (5) or the obturator flat (7)	Clean seat and/or obturator flat
	Worn seat (5) or obturator flat (7)	Replace seat and/or obturator flat
	Line pressure is under 0,3 bar	Contact CSA and replace seat o-ring (3) with softer material (contact CSA)
	Worn seat o-ring (3)	Inspect and replace o-ring (3)
The valve doesn't open completely during negative pressure conditions	The air valve is undersized or the AS spring (17) is blocked due to friction or corrosion.	Contact CSA for assistance with air valves sizing and replace the spring
Valve leaks out of the air release subset (6)	Valve is not vertical	Place the valve in a vertical position (max 3° tilt angle)
	Possible corrosion through the body and air release subset (6)	Check the fluid chemicals parameters and contact CSA
	Dirt accumulated on the air release subset (6)	Inspect and clean the air release subset (6), replace if necessary
	Line pressure is extremely low	Check the pressure acting on the air valve, if possible by using the sensing port (12) and contact CSA



## Guarantee

Products, auxiliaries and parts thereof of CSA srl manufacture are warranted to the original purchaser for a period of twelve (12) months from date of shipment from factory, against defective workmanship and material, but only if properly installed, operated and serviced in accordance with CSA srl recommendations. Repair or replacement, at our option, for items of CSA srl manufacture will be made free of charge, (FOB) our facility with removal, transportation and installation at your cost, if proved to be defective within such time, and this is your sole remedy with respect to such products. No claim for transportation, labor or special or consequential damages or any other loss, cost or damage shall be allowed. You shall be solely responsible for determining suitability for use and in no event shall CSA srl. be liable in this respect. CSA srl does not guarantee resistance to corrosion, erosion, abrasion or other sources of failure, nor does CSA srl guarantee a minimum length of service. Your failure to give written notice to us of any alleged defect under this warranty within twenty (20) days of its discovery, or attempts by someone other than CSA srl. or its authorized representatives to remedy the alleged defects therein, or failure to return product or parts for repair or replacement as herein provided, or failure to install and operate said products and parts according to instructions furnished by CSA srl or misuse, modification, abuse or alteration of such product, accident, fire, flood or other Act of God, or failure to pay entire contract price when due shall be a waiver by you of all rights under this warranty.

The foregoing guarantee shall be null and void if, after shipment from our factory, the item is modified in any way or a component of another manufacturer, such as but not limited to, an actuator is attached to the item by anyone other than CSA srl. factory Service personnel. All orders accepted shall be deemed accepted subject to CSA srl warranty terms and conditions.

## Limitation of liability

LIMITATION OF LIABILITY: IN NO EVENT SHALL CSA srl BE LIABLE FOR ANY DIRECT, INDIRECT, SPECIAL OR CONSEQUENTIAL DAMAGES WHATSOEVER, AND CSA srl LIABILITY, UNDER NO CIRCUMSTANCES, WILL EXCEED THE CONTRACT PRICE FOR THE GOODS AND/OR SERVICES FOR WHICH LIABILITY IS CLAIMED. ANY ACTION BY YOU FOR BREACH OF CONTRACT MUST BE COMMENCED WITHIN 12 MONTHS AFTER THE DATE OF SALE.

## Sales and Service

For information about our service, approvals, certifications:

Web site: [www.csasrl.it](http://www.csasrl.it) E-Mail : [info@csasrl.it](mailto:info@csasrl.it)



*CSA srl Inc. reserves the right to incorporate our latest design and material changes without notice or obligation.*

*Design features, materials of construction and dimensional data, as described in this manual, are provided for your information only.*