

WW-720

Pressure Reducing Control Valve

(Size Ranges: 2''- 4'' and 6''- 14'')

Installation

Operation

& Maintenance

1. DESCRIPTION

The Model 720 Pressure Reducing is an automatic control valve (powered by pipe-line pressure) designed to hydraulically reduce a higher upstream pressure to a lower constant downstream pressure regardless of fluctuating demand and/or varying upstream pressure. It is a pilot controlled, hydraulically operated, diaphragm actuated globe valve in either the oblique (Y) or angle pattern design.

2. PRINCIPAL OF OPERATION

A 2-way pressure-reducing pilot (Model #2 or #2PB) controls the Model 720. The pilot senses the downstream pressure and modulates opening or closing accordingly. This varies the pressure in the upper control-chamber causing the main valve to throttle thus maintaining constant delivery pressure. When the downstream pressure falls below the pilot setting, the pilot changes position, increasing water flow from the control-chamber to valve's downstream. Pressure in the upper control-chamber decreases, and the main valve modulates open to increase downstream pressure and maintain pilot setting. If the downstream pressure rises above the pilot setting, the pilot changes position, decreasing water flow from the control chamber to valve's downstream. Pressure in the upper chamber increases and the main valve throttles close to decrease downstream pressure to the pilot setting. The pressure-reducing pilot has an adjusting screw to set the desired downstream pressure

3. INSTALLATION

Ensure enough space around the valve assembly for future maintenance and adjustments. Flush the pipeline to remove dirt, scale, and debris; otherwise the valve may not operate properly. For future maintenance, install Isolation gate valves upstream and downstream of the Bermad control valve. Install the valve in the pipeline with the valve flow direction arrow in the actual flow direction. Use the lifting ring provided on the main valve cover for installing the valve. For best performance, install the valve horizontally with the cover upright. Ensure that the valve actuator can be removed for maintenance. After installation carefully inspect/correct any damaged accessories, piping, tubing, or fittings.

4. IN LINE STATIC TEST

4.1. Open Valve Static Test

Close cock valve 1 and 2 to isolate the pilot control system. This prevents dirt exposure in the control loop.

Remove the cover plug on the main valve or take off a tube line to the cover.
CAUTION: This will allow the valve to fully open. Make sure this condition will not cause system damage!

Check for leaks at the flange connection, main line fittings, etc.

4.2. Closed Valve Static Test

Close cock valve 2 and open cock valves 1. This will trap the main valve in a closed position while the pipeline is pressurized.

Vent trapped air in the main valve cover by loosening a tube fitting at the highest point on the cover. Retighten.

Check the valve cover and diaphragm area for leaks. Tighten cover bolts if necessary.

5. START-UP OPERATION

NOTE: There must be flow through the valve to make necessary adjustments. Create system conditions that allow the desired flow to be demanded through the valve by opening a hydrant, relief valve, bypass, etc.

1. Close main valve by closing cock valve 2. Cock valve 1 should be open.
2. Turn adjusting screw on pressure reducing pilot (#2 or #2PB) all the way, counter-clockwise.
3. Open cock valve 2. Main valve should remain closed.
3. **Slowly** turn the adjusting screw on pressure reducing pilot (#2 or #2PB) clockwise until the desired downstream pressure is achieved.
4. Pause for a few seconds after each adjustment to allow the valve to react & modulate accordingly. Once the pressure setting is achieved, tighten lock nut.

6. PREVENTATIVE MAINTENANCE SCHEDULE

The following procedure suggestions are a maintenance guide. These procedure suggestions will vary depending on the type of fluid and operation conditions.

<i>Description</i>	<i>Norm</i>
Clean filter	Annually
Seat inspection	Annually
Seal inspection	Biannually or longer
Indicator Stem freedom of rotation	Annually
Valve freedom of movement	Annually
Sealing	Annually
Needle valve operation	Annually
Pressure gauge	Semi Annually
Cavitation damage	Annually
Inspect and/or replace diaphragm heavy duty	3 year
Inspect and/or replace diaphragm light duty	5 year

7. FIELD MAINTENANCE INSTRUCTIONS

Bermad valves require no lubrication, no packing tightening, and require a minimum of maintenance. A periodic inspection schedule should be established to determine how the flow, the erosion, the dissolved minerals and the suspended particles are affecting the valve.

VALVE OVERHAUL. After about three years of operation, replacement of important parts and diaphragm is recommended. Remove the actuator, clean the valve body from sediments, clean the control tubing entry holes, install a new diaphragm and other Elastomers.

FILTER CLEANING. The filter used in the valve is a Y pattern filter. The filter should be cleaned manually every time the valve is opened for internal inspection.

8. PART LIST

Bermad has a convenient and easy to use Ordering Guide for valve spare-parts and control system components. (See attached pages with spare part list and illustrated parts breakdown).

Bermad Company has a complete inventory of parts. Shipment on any part is made the same day the order is received.

Stocking distributors in many regions also have an inventory of parts. Contact your local representative.

It is not recommended to store spare rubber parts for long periods (e.g. years). Rubber in improper storage conditions can harden, have ozone cracking, grow mold bloom and heat aging. Order new rubber parts when required.

9. TROUBLE-SHOOTING

Symptom	Probable Cause	Action
Valve fails to open	Insufficient inlet pressure.	Check/create inlet pressure.
	No downstream demand.	Create demand/flow.
	Insufficient pressure reducing pilot (#2 or #2PB) spring compression.	Turn adjusting screw on pressure reducing pilot (#2 or #2PB) clockwise (CW) increasing spring compression.
	Cock valve 2 is closed	Open cock valve 2
Valve fails to close.	Filter 4 is plugged.	Perform a filter backwash to clean the filter.
	Needle valve (21 or 5) is plugged or closed.	Clean or adjust needle valve
	Cock valve 1 is closed.	Open cock valve 1.
	Excessive pressure reducing pilot (#2 or #2PB) spring compression.	Turn adjusting screw on pressure reducing pilot (#2 or #2PB) counter clockwise (CCW) decreasing spring compression.
	Debris trapped in main valve.	Remove actuator assembly to inspect/remove debris.
	Diaphragm in main valve leaking	Check by opening cover plug. Continuous flow indicates diaphragm leakage.
Valve fails to regulate	Needle valve (21 or 5) is not properly adjusted.	Factory set at 1.5 turns open. Readjust
	Air trapped in main valve cover or pressure reducing pilot (#2 or #2PB) sense line.	Loosen cover tube fitting at highest point or sense-line tube fittings at pressure reducing pilot (#2 or #2PB). Let air escape. Retighten.

10. CONTROL LOOP DIAGRAM

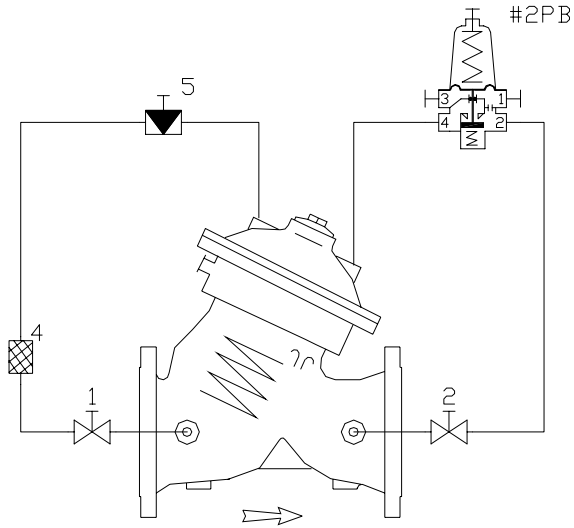

Size Range: 2"-4"

PARTS LIST

- 1 2W Cock Valve
- 2 2W Cock Valve
- 4 Control Filter
- 5 Needle Valve
- #2PB 2W PB PR Pilot

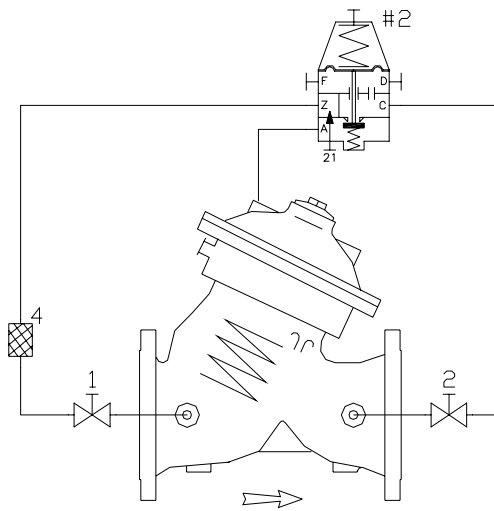

Size Range: 6" -14"

PARTS LIST

- 1 2W Cock Valve
- 2 2W Cock Valve
- 4 Control Filter
- #2 2W P.R. Pilot

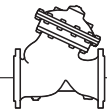

Diaphragm Actuated Basic Control Valves

Sizes: 4"-20"

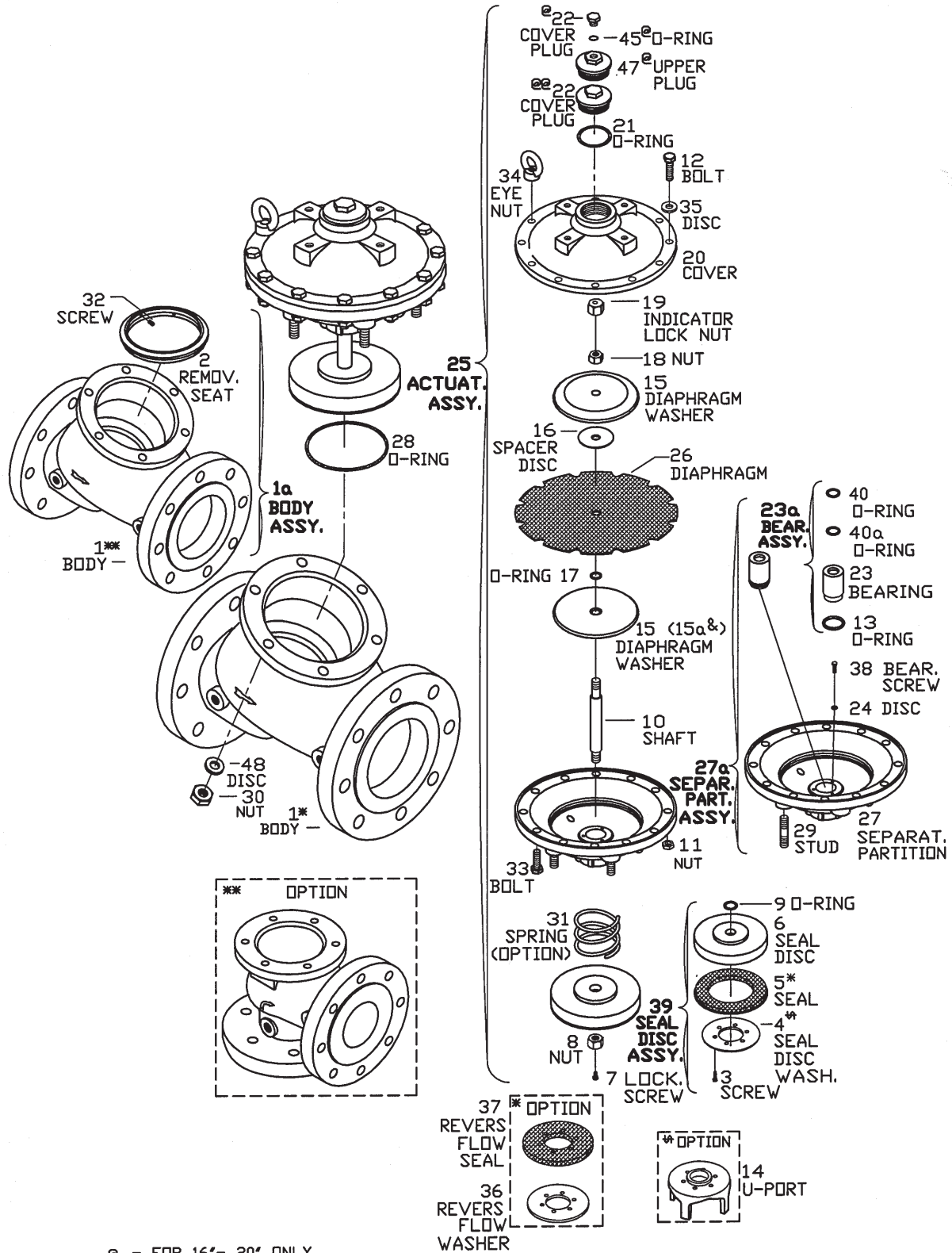

⊕ - FOR 16"- 20" ONLY
 ⊕⊕ - FOR 4"- 14" ONLY
 & - FOR HIGH PRESSURE ONLY

#2 2-way Pressure Reducing Pilot Valve

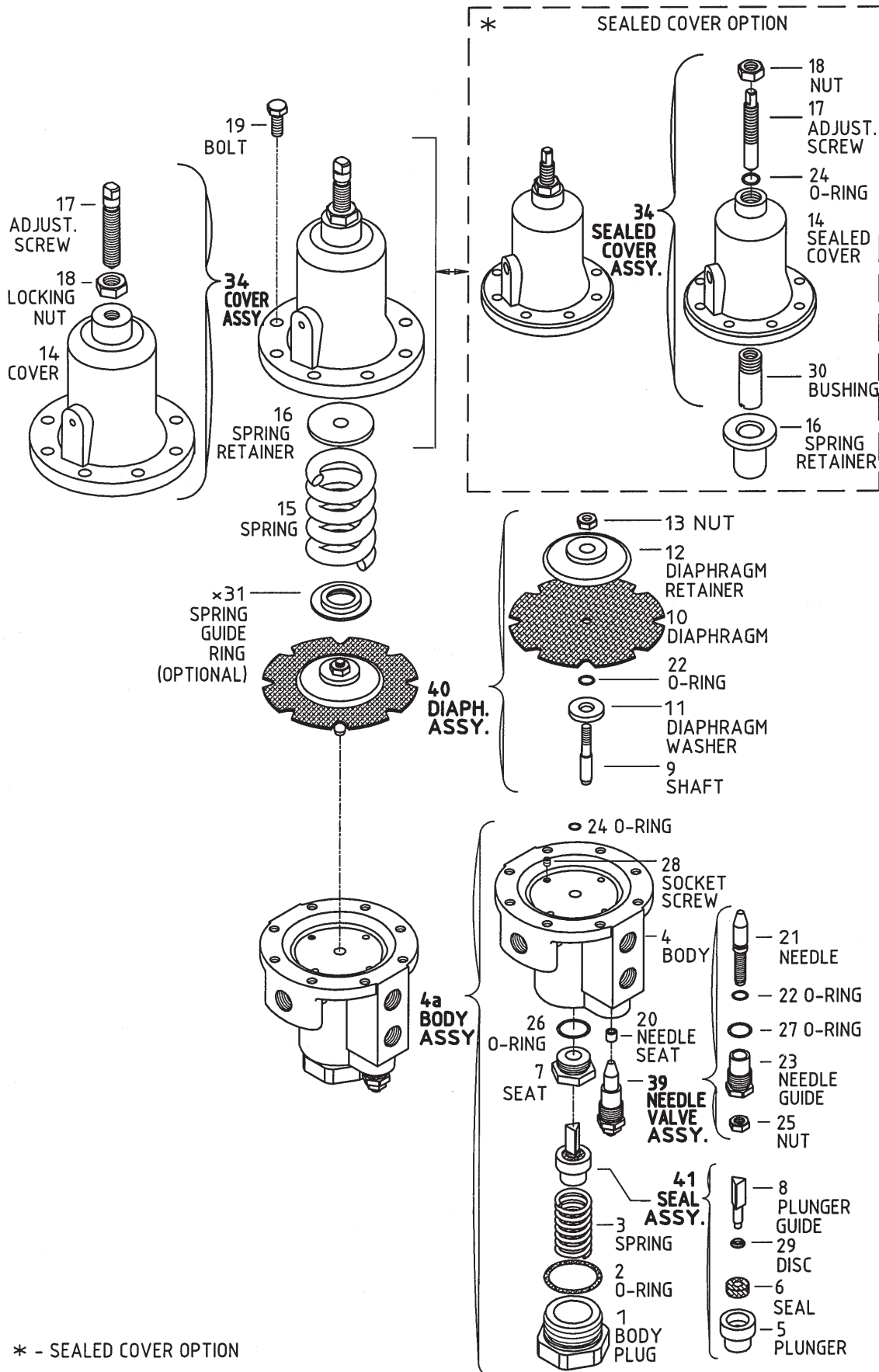

* - SEALED COVER OPTION

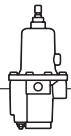

#2PB 2-way Pressure Reducing Pilot Valve

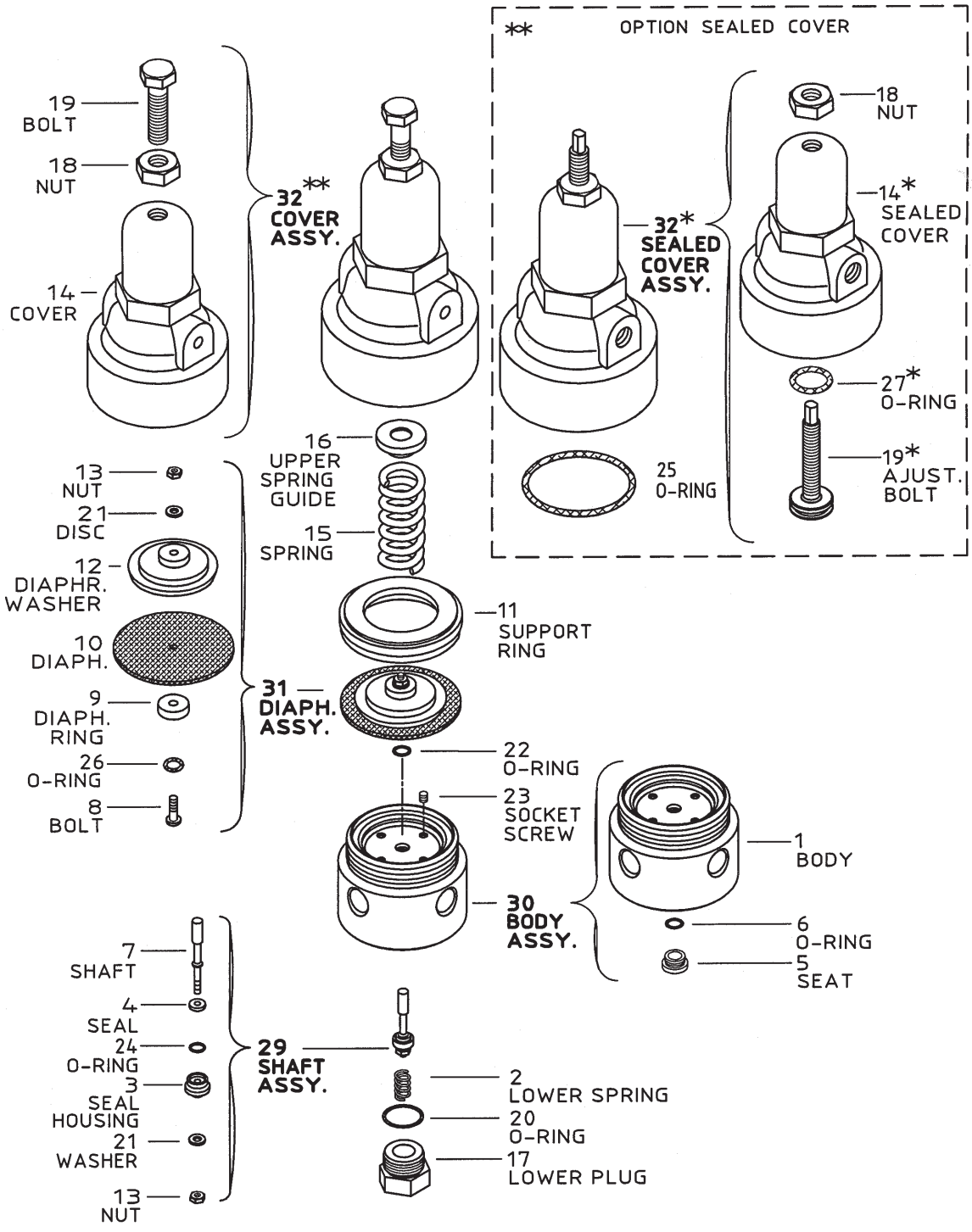

* - FOR SEALED COVER ONLY



Large Control Filter

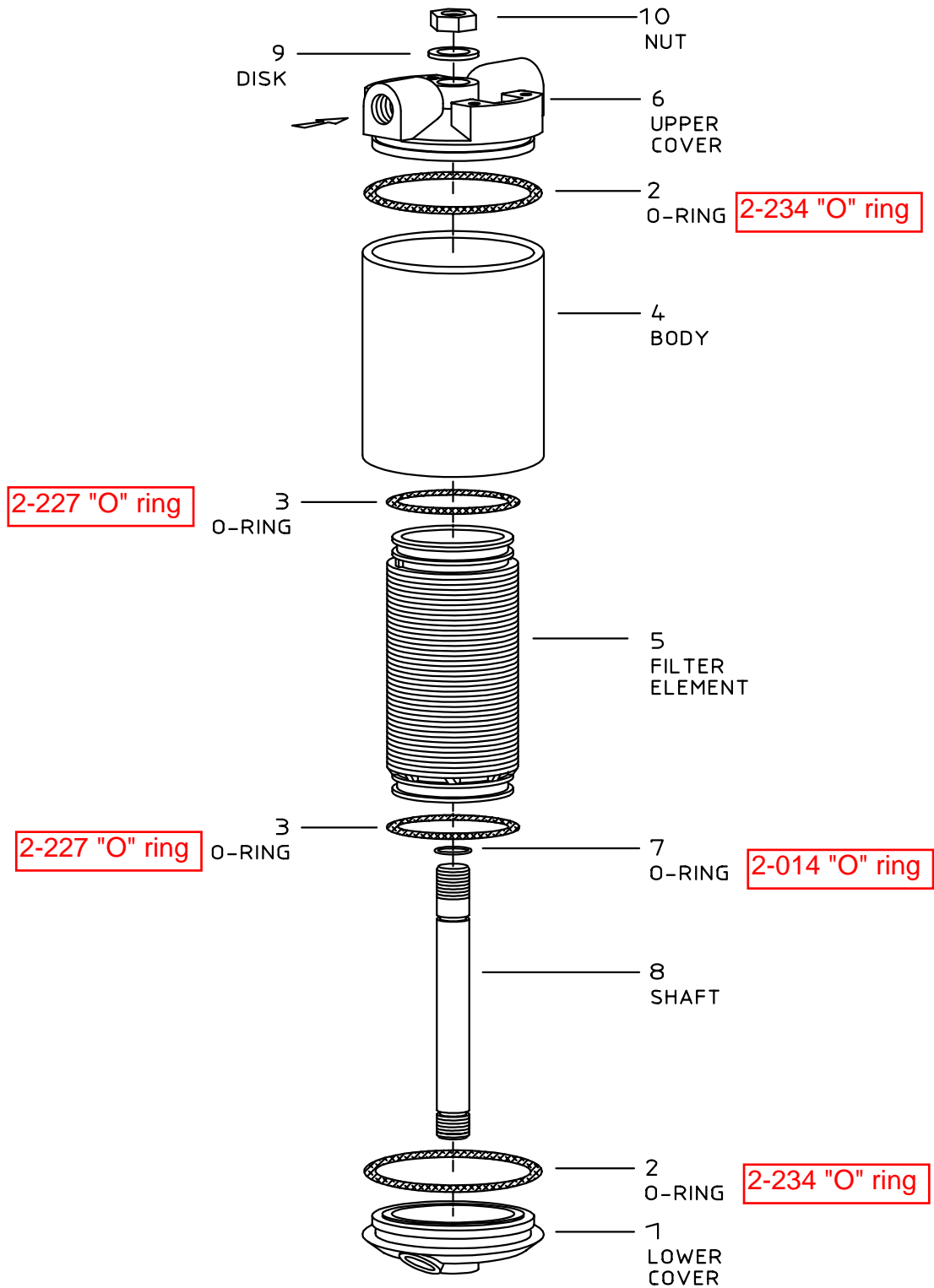

WW-700 Series Elastomers

Created 1.8.2009

Updated 5.8.09

Page Number	700	Part No.		Part No.		Part No.		Part No.		Part No.		Part No.		# KIT Item No.
		O-ring code # Item No. (Qty - 1)	O-ring code # Item No. (Qty - 2)	O-ring code # Item No. (Qty - 1)	O-ring code # Item No. (Qty - 2)	O-ring code # Item No. (Qty - 1)	O-ring code # Item No. (Qty - 2)	O-ring code # Item No. (Qty - 1)	O-ring code # Item No. (Qty - 2)	O-ring code # Item No. (Qty - 1)	O-ring code # Item No. (Qty - 2)	Material # Item No. (Qty - 1)	Material # Item No. (Qty - 1)	
38	1.5"-2.5" DN40-DN65	2-232	8	29	13	21	26	(p.41 p.43)	5	2520-00000				
		0535171232	0527172130	0517172007	0517172007	0526172310	25200B0510	0517172012	25200B2503					
39	3" DN80	2-237	8	13	35	21	26	(p.41 p.43)	5	2530-00000				
		0535171237	0527172130	0517172007	0517172007	0526172310	25300B0312	0517172012	25300B2506					
40	4" DN100	2-246	40	13	17	21	26	(p.41 p.43)	5	2540-00000				
		0535171246	0527172130	0526172466	0526172466	0526172310	22400B0026	0517172012	25400B2322					
40	6" DN150	2-364	40	13	17	21	26	(p.41 p.43)	5	2560-00000				
		0535171364	0535172061	0526172171	0527172130	0535172365	22600B0026	0517172012	25600B2305					
40	8" DN200	2-372	40	13	17	21	26	(p.41 p.43)	5	2580-00000				
		0535171372	053517216	0526172566	0526172111	0535172365	22801B0026	0517172012	25800B2305					
40	10" DN250	2-379	40	13	17	21	26	(p.41 p.43)	5	2510-00000				
		0535171379	0535172034	0526172160	0526172166	0535172365	22011B0026	0517172012	25010B2305					
40	12" DN300	2-456	40	13	17	21	26	(p.41 p.43)	5	2512-00000				
		0569171456	0553172027	0535172365	0526172466	0535172365	25120B0326	0517172012	25120B2305					
40	16"-20" DN400-500	2-466	40	13	17	21 + 45	26	(p.41 p.43)	5	2516-00000				
		0569171466	0553171333	0553171340	0535171223	0535172125 (21) & 0526172310 (45)	25160B0326	0517172012	25160B2305					

* Please note that some items may be used for various sizes and positions.
 * Data correct at "Updated" date only, please consult factory for updated data.