



Main characteristics

- Hermetically sealed register (IP 68)
- Patented hydrodynamically balanced rotor (\leq DN 300)
- Patented symmetrical calibration adjustment (\leq DN 300)
- Register may be rotated through 360°
- High overload capability
- Pattern approved removable measuring element
- Powder coating affords max. corrosion protection
- Not affected by external magnetic fields
- Register display KL
- Australian Standard lengths
- ISO lengths
- Range exceeds Australian Standard AS3651.1 measurement class 2 requirements
- Test certificates provided

Application

Measurement of high, relatively constant flow rates, e.g. behind pumps

Available options

Up to 3 pulsers (1 x OD, 2 x RD) may be fitted without breaking the approval seal

1/4" connection port for pressure sensors

May be equipped with 3 different electronic registers



HYBRID



ELECTRONIC



ENCODER

Cold water meters pressure rate PN 40 please see special leaflet

Pattern Approval Sign

D95	Nominal Diameter DN 40 ... DN 300
6.132.36	Marking: Metrological class B 30 °C
D80	Nominal Diameter DN 400
6.132.01	Marking: Metrological class B 30 °C

Installation

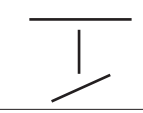
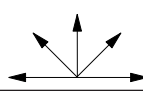
Pipe	horizontal vertical inclined	
Meter head	upwards sideways	

Installation Requirements

Unrestricted straight pipe in front of the meter 3 x DN (DN400 5 x DN)
No abrupt restrictions directly behind the meter

Performance Table

Performance data WP-Dynamic 50 °C

Nominal Diameter		DN	40	50	65	80	100	125	150	200	250	300	400
Size of meter (acc. to EEC)		Q_n	10	15	25	40	60	100	150	250	400	600	1000
Q_{max}	maximum peak flow once in life time 24 h Q_{max} or 5 min. 1,2 x Q_{max} ($\pm 2\%$)	m^3/h	60	90	120	200	300	350	600	1200	1600	2000	3000
Q_n	continuous flow ($\pm 2\%$)	m^3/h	40	50	70	120	230	250	450	800	1250	1400	2000
Q_t	transitional flow ($\pm 2\%$)	m^3/h	0.8	0.7	0.8	0.8	1.8	2.0	4.0	6.0	11.0	15.0	50
Q_{min}	minimum flow ($\pm 5\%$)	m^3/h	0.30	0.30	0.40	0.50	0.80	1.00	1.8	4.0	6.0	12.0	25
	starting flow	m^3/h	0.15	0.15	0.20	0.25	0.25	0.5	1.0	1.5	3.0	8.0	15

Performance data according to EEC-specification 30 °C class B

Nominal Diameter		DN	40	50	65	80	100	125	150	200	250	300	400
Size of meter (acc. to EEC)		Q_n	10	15	25	40	60	100	150	250	400	600	1000
Q_{max}	maximum peak flow short time	m^3/h	30	30	50	80	120	200	300	500	800	1200	2000
Q_n	continuous flow	m^3/h	15	15	25	40	60	100	150	250	400	600	1000
Q_t	transitional flow	m^3/h	3.0	3.0	5.0	8.0	12.0	20.0	30	50	80	120	200
Q_{min}	minimum flow	m^3/h	0.45	0.45	0.75	1.20	1.80	3.00	4.5	7.5	12.0	18.0	30

Typical Accuracy Curve

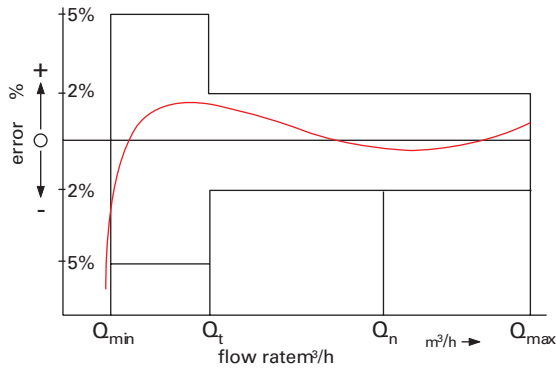

- Q_{max} = maximum peak flow
- Q_n = continuous flow
- Q_t = transitional flow $\pm 2\%$
- Q_{min} = minimum flow $\pm 5\%$

Typical Head Loss Curve

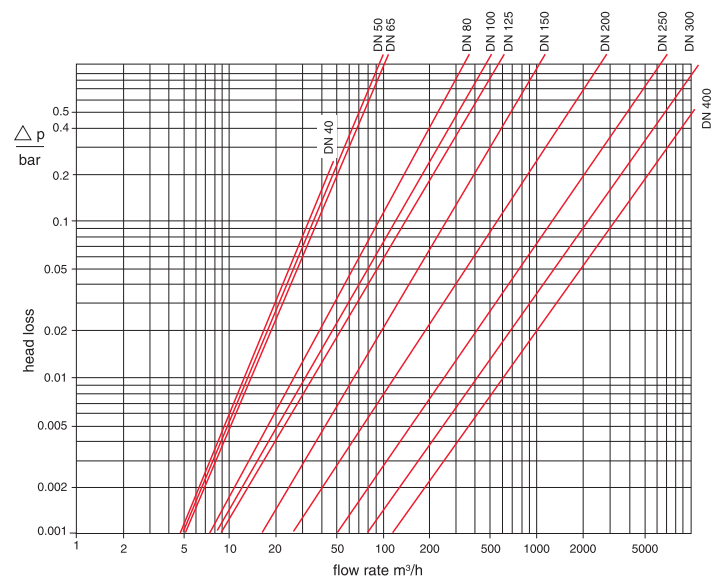

Dimensions and Weights

Nominal Diameter		DN	40	50	80	100	150	150	200	250	300	400
Size of meter (acc. to EEC)		Q_n	10	15	40	60	500	150	250	400	600	1000
Dimensions	overall length	L *)	mm	220	311	413	483	300	500	350	450	500
	height	H	mm	120	120	150	150	177	177	206	231	256
		h	mm	69	73	95	105	135	135	162	194	226
		g	mm	200	200	270	270	356	356	441	466	491
Weights	meter	kg	7.4	7.7	14.0	18.0	30.9	35.5	50.5	72.3	99.3	
	measuring element	kg	1.4	1.4	3.0	3.0	5.9	5.5	7.5	7.5	7.5	
	body	kg	6.0	6.3	11.0	15.0	35	38.3	43.0	63.8	91.8	

*) Other overall lengths on request

Dimension Picture

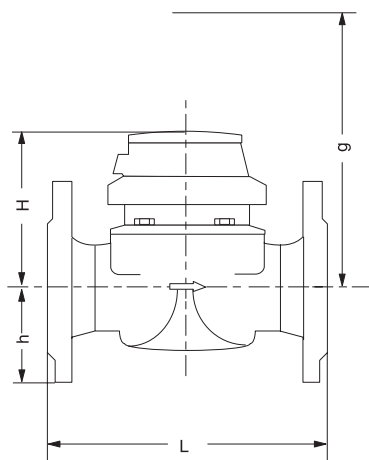

Materials

Body	PN16	cast iron
Measuring element		plastic
Rotor		plastic
We also use the following materials		brass stainless steel

Dials



DN 40 ... DN 125

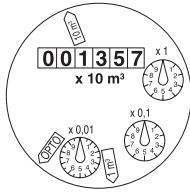

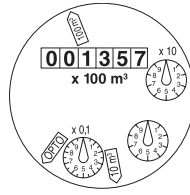

DN 150 ... DN 300



DN 400

Diameter Nominal DN	Smallest reading m ³	Max. reading m ³
50 ... 125	0.0005	1 000 000
150 ... 300	0.005	10 000 000
400	0.05	100 000 000

Pulse Values

Pulser		pulse value		
		DN 40 ... DN 125	DN 150 ... DN 300	DN 400
RD 01		0.01 and 1 m ³	1 and 10m ³ alternative option 0.1 and 10m ³	10 and 100 m ³
OD 01		0.001 m ³	0.01 m ³	0.1 m ³
OD 03		0.01 m ³	0.1 m ³	1 m ³

Order Example

WP-Dynamic, DN 50, 50/16, L= 311 mm, 1/0.1 m³ _____ type
 drilled according to EN 1092 PN 16 _____ diameter nominal
 828595 _____ working temperature
 _____ pressure rate
 _____ overall length
 _____ pulse values
 _____ flange drilling
 _____ order no.

Bermad Water Technologies
 Ph (03) 9464 5421
 www.bermad.com.au



Certified according to ISO 9001
 Quality Management System OQS Reg.no. 3496/0

UK & Ireland Enquiries

Sensus Metering Systems 11 The Quadrangle, Abbey Park, Romsey, Hampshire SO51 9DL UK
 T: +44 (0) 1794 526100 F: +44 (0) 1794 526101 Email: info.gb@sensus.com www.sensus.com

International Enquiries

Sensus Metering Systems GmbH Hannover Meineckestraße 10, D-30880 Laatzen Germany
 T: +49 (0) 5102 74-0 F: +49 (0) 5102 74-3341 Email: info.int@sensus.com www.sensus.com