



Combination air valve Mod. FOX 3F - HP

The CSA air valve Mod. FOX 3F HP will ensure the proper operation of the pipeline network allowing the release of air pockets during working conditions, the evacuation and entrance of large volumes of air during filling and draining operations.



Technical features and benefits

- Body in carbon welded steel, PN 64 bar rated, provided with internal spacers for consistent and accurate guiding of the mobile block.
- In general supplied with fixed flanges according to EN 1092/2 or different on request.
- Mobile block composed of a cylindrical float and upper disk in solid polypropylene, joined together by the CSA air release system in AISI 316 (pat. Pending). The solid cylindrical floats, obtained by CNC machining, avoid deformations and ensure a great sliding precision inside the body processed ribs and a perfectly vertical thrust.
- Nozzle and gasket holder, part of CSA air release system, entirely made in AISI 316 and designed with gasket compression control to prevent aging process and consequent leakage during working conditions.
- Maintenance can be easily performed from the top, without removing the air valve from the pipe.
- Mesh and cap in stainless steel.

Applications

- Main transmission lines.
- Mines.
- Dams and high pressure systems
- In general this model is used on changes in slope descending and at the high points of the pipeline for those locations exposed to high pressure conditions when ductile cast iron is not acceptable.

Operating principle

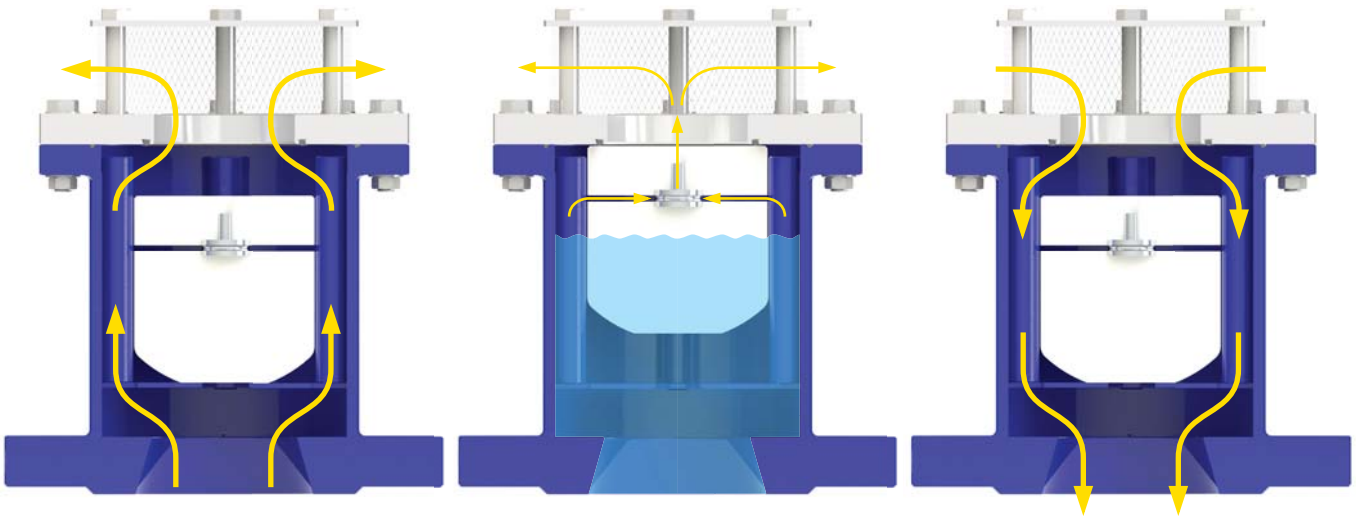

Discharge of large volumes of air

During the pipe filling it is necessary to discharge air as water flows in. The FOX 3F HP, thanks to an aerodynamic deflector, will make sure to avoid premature closures of the mobile block during this phase.

Air release during working conditions

During operation the air produced by the pipeline is accumulated in the upper part of the air valve. Little by little it is compressed and the pressure arrives to water pressure, therefore its volume increases pushing the water level downwards allowing the air release through the nozzle.

Entrance of large volumes of air

During pipeline draining, or pipe bursts, it is necessary to bring in as much air as the quantity of outflowing water to avoid negative pressure and serious damages of the pipeline, and to the entire system.

Optional



■ **Vacuum breaker version Mod. FOX 2F HP** to allow the entrance and discharge of large volumes of air only. This model is normally recommended in changes in slope ascending, long ascending segments, dry fire systems, and wherever the air release won't be required.



■ **Version for submerged applications, SUB series**, available both for FOX 3F HP and 2F HP Models, with elbow for air conveyance. The design sprang from the necessity of having an air valve performing also in case of flood, without the risk of contaminated water entering the pipeline. Another benefit of SUB is to avoid the spray effect, conveying spurts coming from the rapid closure of the air valve.



■ **Version for air discharge only EO series**, available both for FOX 3F HP and 2F HP models. The most important application of EO is to allow the air valve installation in those locations of the system where HGL may drop below the pipe profile, and to any other node where for project requirements air entrance must be avoided.



■ **Version for air entrance only IO series**, available for FOX 2F HP model only. The most important application of IO is to allow the air valve installation in those locations of the system where, for project requirements, air discharge and release must be avoided.

Air flow performance charts

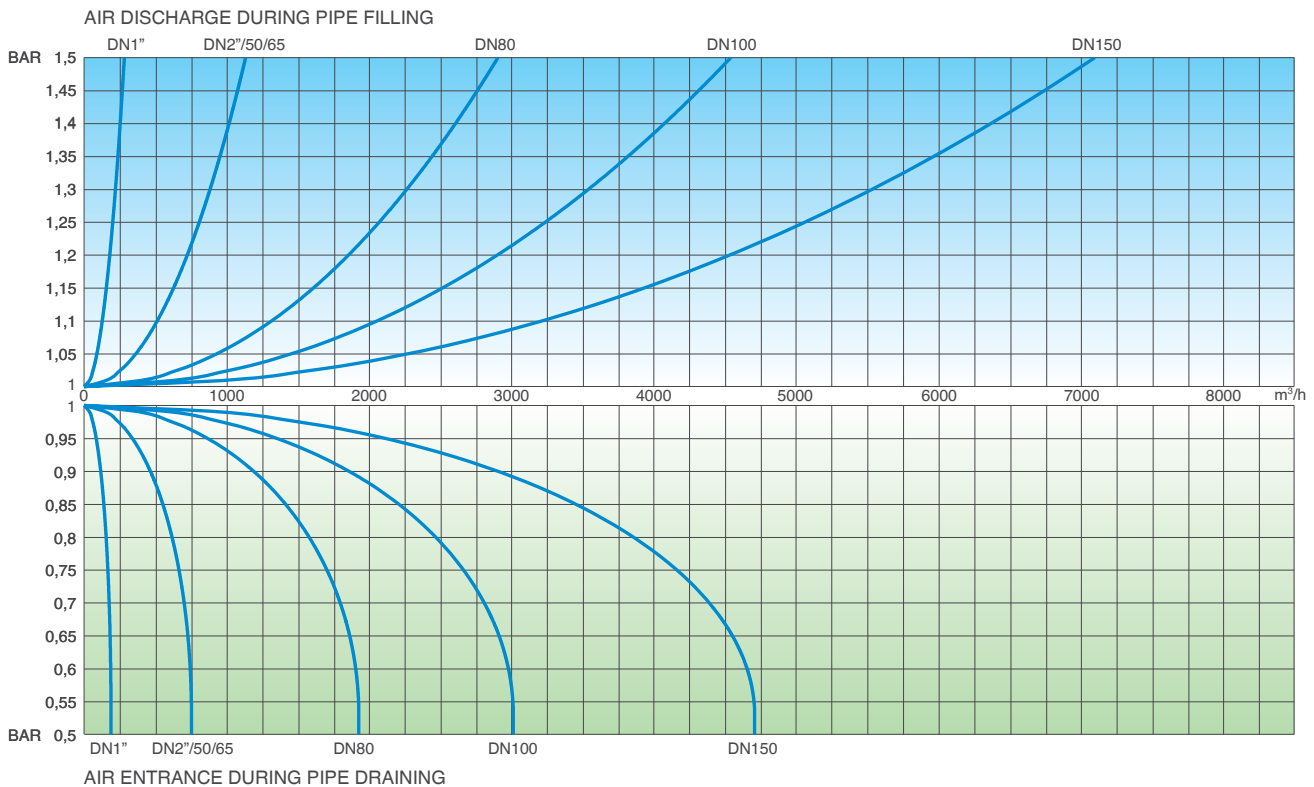

Working conditions

Treated water 70° C max.;
 Maximum pressure 64 bar;
 Minimum pressure 0,2 bar;

Standard

Designed in compliance with EN-1074/4.
 Flanges according to EN 1092/2, ANSI.
 Epoxy painting applied through fluidized bed technology blue RAL 5005.
 Changes and variations on the flanges and painting details available on request.

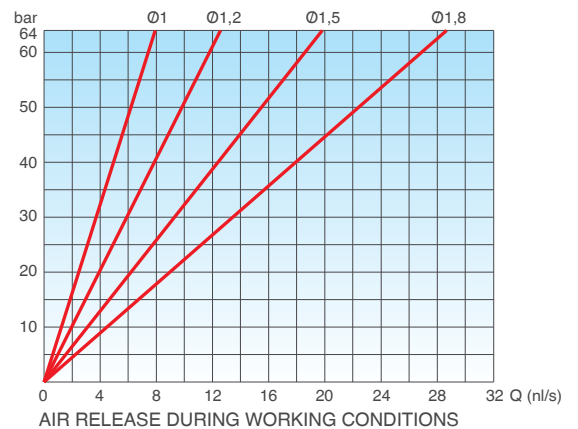

CONNECTION inch/mm	A mm	B mm	C mm	Weight Kg
Threaded 1"	165	240	180	4,2
Threaded 2"	165	240	180	5,0
Flanged 50	165	240	180	6,0
Flanged 65	185	240	180	6,0
Flanged 80	200	265	205	9,2
Flanged 100	235	334	205	13,0
Flanged 150	300	380	250	35,0

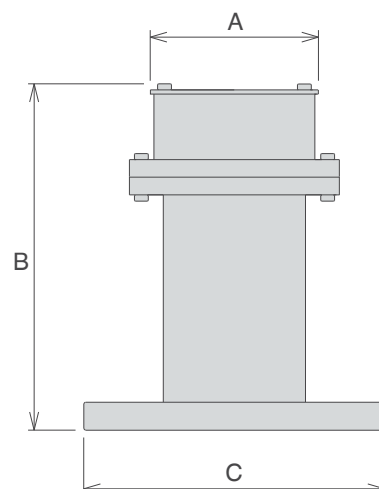

Technical details

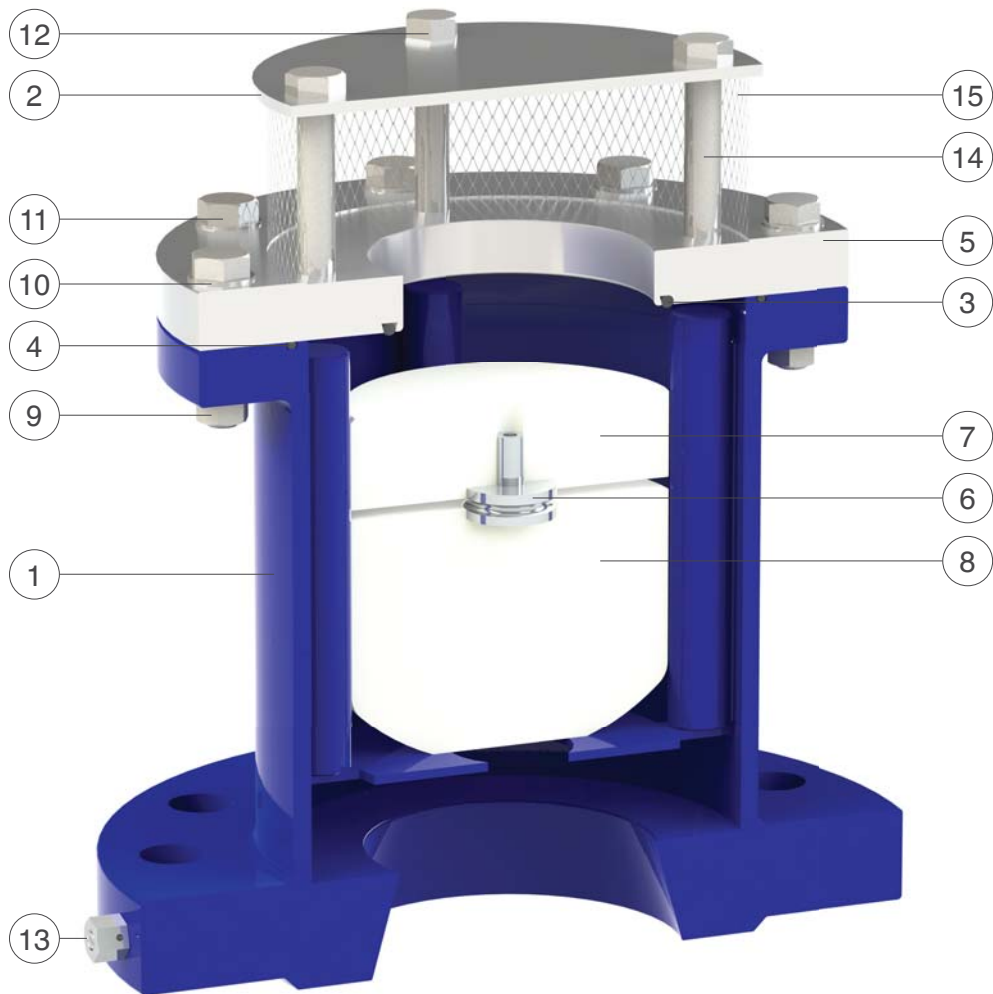

N.	Component	Standard material	Optional
1	Body	painted steel Fe 37	
2	Cap	stainless steel AISI 304	stainless steel AISI 316
3	O-ring	NBR	EPDM/Viton/silicone
4	O-ring	NBR	EPDM/Viton/silicone
5	Seat	stainless steel AISI 304	stainless steel AISI 316
6	Nozzle Subset	stainless steel AISI 316	
7	Upper flat	polypropylene	
8	Float	polypropylene	
9	Nut	stainless steel AISI 304	stainless steel AISI 316
10	Washers	stainless steel AISI 304	stainless steel AISI 316
11	Screws	stainless steel AISI 304	stainless steel AISI 316
12	Screws	stainless steel AISI 304	stainless steel AISI 316
13	Drain valve	stainless steel AISI 303	stainless steel AISI 316
14	Spacers	stainless steel AISI 304	stainless steel AISI 316
15	Filter	stainless steel AISI 304	

The list of materials and components is subject to changes without notice.