

Pressure Reducing Valve

Model: FP 420-00



Description

The Model FP 420-00 Pressure Reducing Valve is a hydraulically self operated, diaphragm actuated control valve that reduces high, unstable upstream pressure to maintain precise stable downstream pressure, regardless of fluctuating demand or varying upstream pressure.

Typical Applications



Hose station feeds



Sprinkler systems with over pressure



Deluge systems with over pressure



Foam systems



Fire hydrant water supply

Features and Benefits

- **Advanced Elastomeric Globe type** – Low pressure loss
- **One-piece molded single moving part** – No maintenance required
- **Simple design** – Cost effective
- **Factory pre-assembled trim** – Out-of-Box Quality
- **In-line serviceable** – Minimal down time

Optional Features

- Large control filter (code: F)
- Seawater service

Note: Optional features can be mixed and matched. Consult your Bermad representative for full details

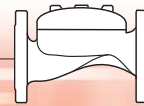

Operation

The BERMAD Model FP 420-00, pilot operated pressure reducing valve automatically and accurately reduces upstream water pressure to a specific, adjustable value. The FP 420-00 operates under both flowing and non-flowing (static) conditions. The Pressure Reducing Pilot [1] senses downstream pressure [2] and in real time modulates the main valve [3] to maintain the constant downstream pressure.

In no-flow static conditions, should the downstream pressure start rising above pilot setting, the pilot closes, shutting the main valve bubble-tight [4] to maintain the allowable downstream pressure.

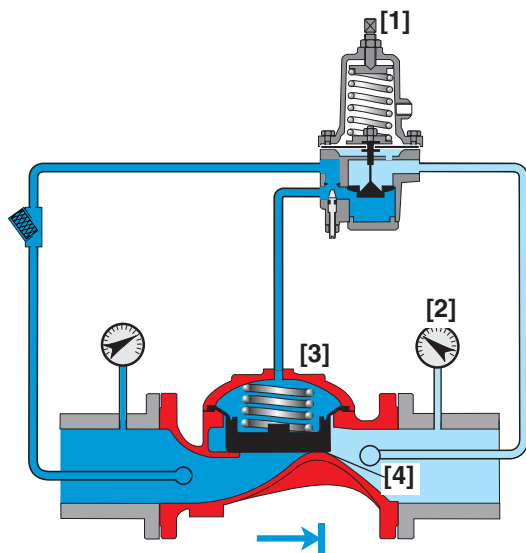

Valve Closed (static condition)

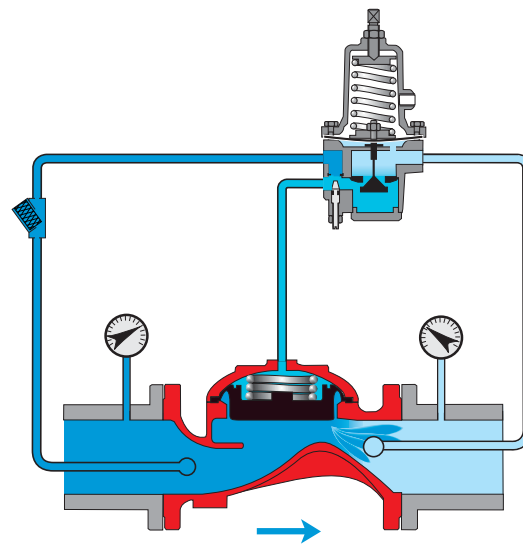

Valve Open (flowing condition)

Engineer Specifications

The pressure reducing valve shall eliminate downstream over-pressure, maintaining a constant downstream delivery pressure, regardless of varying pressures and/or flows.

The main valve shall be an elastomeric type globe valve with a rolling-diaphragm.

Valve actuation shall be accomplished by a fully peripherally supported, one-piece balanced rolling-diaphragm, vulcanized with a rugged radial seal disk. The diaphragm assembly shall be the only moving part.

The valve shall have an **unobstructed flow path**, with no stem guide or **supporting ribs**.

The valve shall have a removable cover for quick in-line service enabling all necessary inspection and servicing.

The control trim shall be supplied as an assembly, pre-assembled and hydraulically tested at an ISO 9000 and 9001 certified factory.

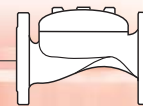

Typical Installations

System Components

Standard Pressure Reducing System

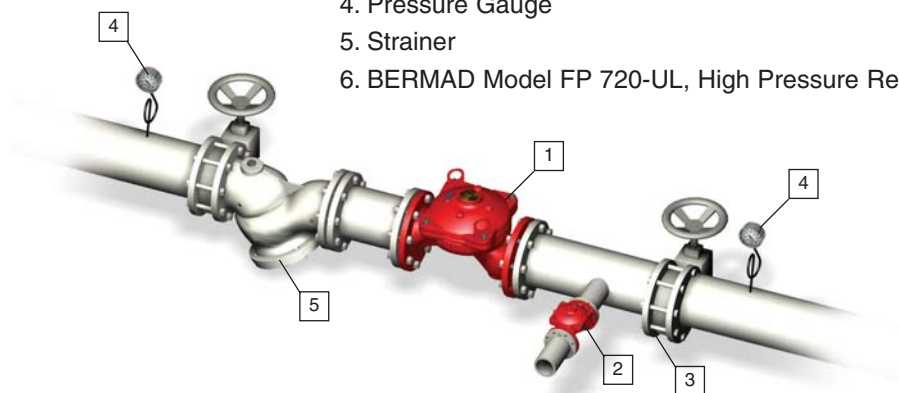

1. BERMAD Model FP 420-00
2. BERMAD Model FP-430-UF Pressure Relief Valve
3. Isolating Valve
4. Pressure Gauge
5. Strainer
6. BERMAD Model FP 720-UL, High Pressure Reducing Valve

Parallel Pressure Reducing System

- Wide flow range
- Redundant safety
- Serviceable with zero down time

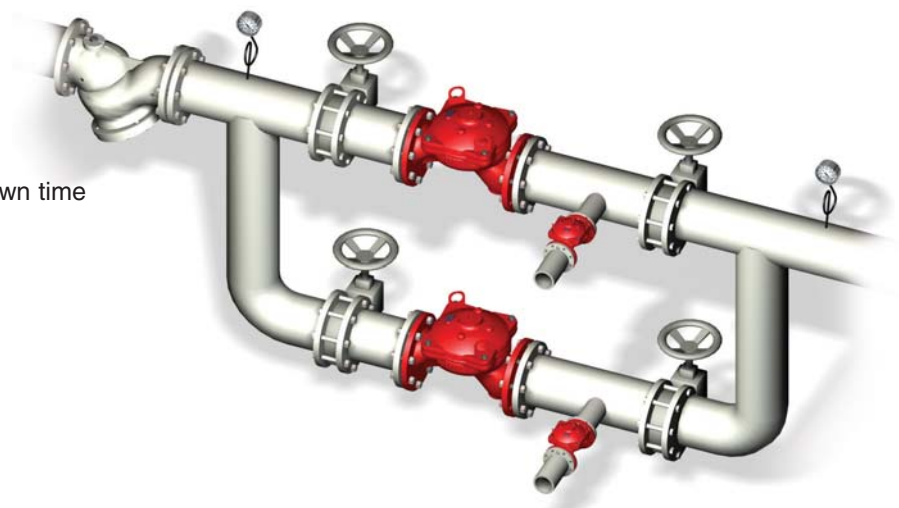

Two-Stage Pressure Reducing System

- High pressure differential
- Added reduced pressure zone protection

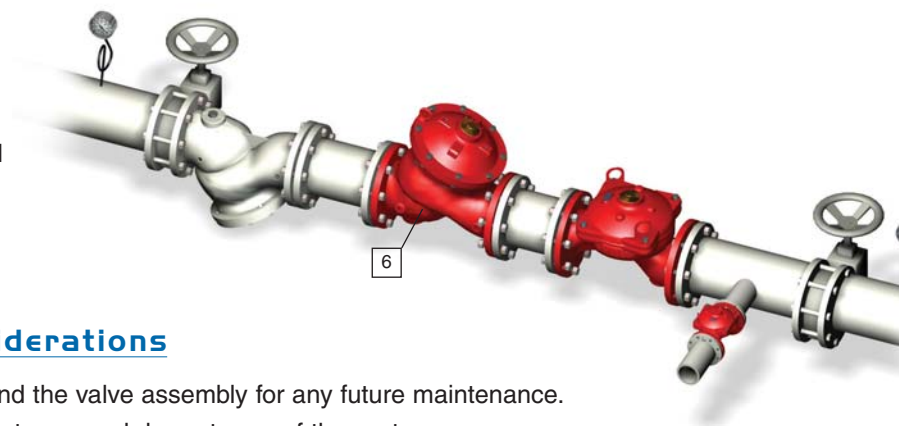

Installation Considerations

- Allow enough room around the valve assembly for any future maintenance.
- Install isolating valves upstream and downstream of the system.
- Install the valve horizontally with the cover up.
- Install a relief valve (recommended: BERMAD Model FP 430-UF) of the appropriate size on the downstream side of the FP 420-00, as required by NFPA-20 standard.
- Install a pressure gauge on both sides of the system.

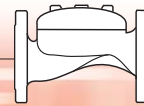

Technical Data

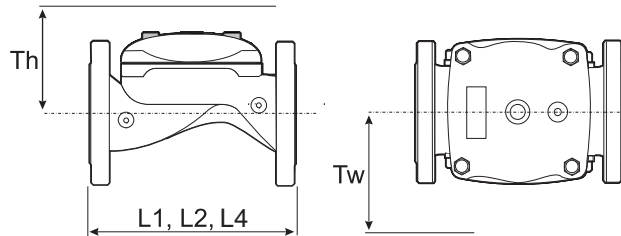

Valve Size		2"		2½"		3"		4"		6"		8"		10"		12"	
		mm	inch	mm	inch	mm	inch	mm	inch	mm	inch	mm	inch	mm	inch	mm	inch
Dimension	(1)L1	205	8½	205	8½	250	9⅞	320	12⅞	415	16⅝	500	19⅞	605	23⅞	725	28½
	(2)L2	180	7⅞	210	8¼	255	10⅞	N/A	N/A	N/A	N/A	N/A	N/A	N/A	N/A	N/A	N/A
	(2)L4	180	7⅞	210	8¼	255	10⅞	N/A	N/A	N/A	N/A	N/A	N/A	N/A	N/A	N/A	N/A
	Tw	284	11⅜	284	11⅜	300	11⅞	313	12⅝	341	13⅞	415	16⅝	443	17⅞	481	18⅞
	Th	210	8¼	210	8¼	215	8⅞	243	9⅞	315	12⅞	350	13¾	382	15	430	6⅞

Notes:

- L1 is for flanged valves.
- L2 is for threaded NPT or BSP.
- L4 is for Grooved Valves.
- Tw & Th are max. for pilot system.
- Data is for envelope dimensions, component positioning may vary.
- Provide space around valve for maintenance.

Connection Standard

- Flanged: ANSI B16.42 (Ductile Iron), B16.5 (Steel & Stainless Steel), B16.24 (Bronze)
- ISO PN16
- Threaded: NPT or BSP for 2, 2½ & 3"
- Grooved: ANSI/AWWA C606 for 2, 3, 4 & 6"

Water Temperature

- 0.5 – 50°C (33 – 122°F)

Available Sizes

- Globe: 2, 2½, 3, 4, 6, 8, 10 & 12"

Pressure Rating

- Max. inlet: 250 psi (17 bar)
- Set: 30 - 165 psi (2 - 11.5 bar)
- Test : 365 psi (25 bar)

Approvals

- ABS
- Lloyd's Registered

Manufacturers Standard Materials

Main valve body and cover

- Ductile Iron ASTM A-536

Main valve internals

- Stainless Steel & Elastomer

Control Trim System

- Brass control components/accessories
- Stainless Steel 316 tubing & fittings

Elastomers

- Polyamide fabric reinforced Polyisoprene, NR

Coating

- Electrostatic Powder Coating Polyester, Red (RAL 3002)

Optional Materials

Main valve body

- Carbon Steel ASTM A-216 WCB
- Stainless Steel 316
- Ni-Al-Bronze ASTM B-148

Control Trim

- Stainless Steel 316
- Monel® and Al-Bronze
- Hastelloy C-276

Elastomers

- NBR
- EPDM

Coating

- High Built Epoxy Fusion-Bonded with UV Protection, Anti-Corrosion

