

Electromagnetic Flowmeter



Sensor Wafer MUT 1000 EL

DS120-1-ENG 

Sensor MUT 1000 EL

MUT 1000 EL sensors represent the state of the art of EUROMAG INTERNATIONAL production for water cycle and process applications.

The new structure for the generation of the magnetic field, the innovative route of the signal generated by the electrodes, is giving a sensor with an extremely wide measurement range, keeping the extremely compact dimensions.

EL= Extended Linearity.

This new sensors series follows the successful tradition of the MUT 1000, introducing a measurement range of more than 1:1000 without linearization software.

These kinds of performances allow doing very accurate measures on a wide flow rate range and to count lower flow rates that before would have been reset because of the effect of the converters cut off.

This flanged sensors series bases its operation on the Faraday Principle, by which a conductor crossing a magnetic field generates a potential perpendicularly orientated to the same field. In this case the flow tube made in stainless steel AISI 304, two coils are installed on the top and inferior part; the magnetic field, generated by the electric current crossing the coil, induces in the electrodes a difference in the potential proportional to the flow rate. With the aim of measuring such potential of very low values, the interior of the flow tube is electrically insulated, thus the process liquid is no longer in contact with the material of the flow tube.

The converter used generates the current supplying the coil, acquires the electrodes difference of potential, processes the signal to calculate the flowrate and manages the communication with the exterior.

The entire sensor, when installed in the separate version, has a degree of protection IP 68 suitable for a permanent immersion in water up to a depth of 1.5m, thanks to a welded plate structure containing the coil and the electrodes.

1. Body and connection

MUT 1000EL SENSORS have the flow tube made in stainless steel AISI 304 and the structure is made in acrylic painted carbon steel. This treatment gives the sensor an excellent resistance to water, even in permanent immersion. It is equipped with a junction box to connect the cables to the converter. Its standard degree of protection is IP68, suitable for a permanent immersion in water at 1,5m. It is installed between flanges UNI 2223 from PN 16 to PN 40 or between flanges ANSI 150, 300.

2. Internal lining

The standard internal insulating lining is in PTFE for diameters from ND 25 to ND 150, in hard rubber for food stuff (ebonite for food) for diameters of more than ND 150. On request the sensors may be supplied coated with PTFE for diameters of more than ND 150. The temperature of the liquid to be measured is limited by the kind of internal lining used.

3. Electrodes and grounding

The standard electrodes are in Hastelloy C and, therefore, guarantee a wide compatibility with the process liquids, if required they may be supplied in the materials shown in Table 2. If these sensors are inserted in a plastic or lined pipe line, they require the use of two grounding rings for the liquid, which are inserted at each side of the sensor or the installation of the grounding electrode.

An empty pipe electrode may also be provided on request to monitor conditions of partly filled pipe.

4. Coupling and connecting to sensor

MUT 1000 EL sensors may be coupled with any EUROMAG converters shown in Table 3. In the separate version the sensor is connected to the converter by means of two cables whose length depend on the liquid conductivity; the maximum length not exceeding 100 metres as shown in Figure 1.

5. Choice of diameter

In order to select the correct diameter use figure 3, the recommended full scale velocity, in normal applications, is around 2÷3 m/s. It should be noted that the full scale flowrate can be selected in the field through the converter keyboard. The maximum value that may be selected is the one corresponding to a velocity of 10 m/s.

6. Maximum temperature of the liquid

In the separate version the maximum liquid temperature allowed is 180°C. In the compact version instead, the maximum temperature allowed depends on the ambient temperature. This is due to the required cooling of the electronics. The maximum liquid temperature allowed for the compact version should be 80°C. Maximum operating temperature for ebonite lined sensors is 80°C.

7. Calibration and maximum error

MUT1000 EL sensors belong to the reference Group B1 (ISO 11631). Each sensor is calibrated by a hydraulic bench equipped with a reference weighting system and SIT certified. The uncertainty of the measure is equal to 0.2% of the read flowrate value when the velocity of the liquid is more than 0.2 m/s. The repeatability of the measure is in the order of 0.1%.

8. Reference standards

The EUROMAG magnetic meters are marked CE and are manufactured according to the following standards:

- * CEI EN 61010-1
- * UNI EN ISO 6817
- * EN 1434
- * EN 50081 - 1
- * EN 50082 - 1
- * 2006/95/CE, 93/68 (LVD)
- * 2004/98/CE, 92/31 (EMC)

Converters coupling

Version of MUT1000 EL	MC 106 A	MC 106 B	MC 308	MC 308 C	MC 108	MC 608
	[1]	[1]	[1] [2]	[2]	[2]	[2]
SEPARATE	●	●	●	●	●	●
COMPACT	●		●	●	●	●

[1] Case in abs [2] Case in aluminium [3] Case in stainless steel

table 3

Maximum length of cables according to the liquid conductivity

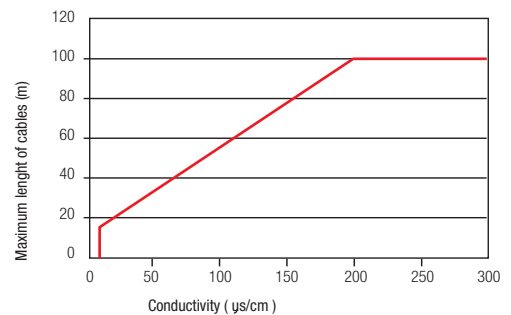

figure 1

Diametri standard

millimetri (mm)	25	40	50	65	80	100	125	150	200	250	300
pollici (")	1"	1.1/2"	2"	2.1/2"	3"	4"	5"	6"	8"	10"	12"

table 1

Available electrodes

* Hastelloy C (standard)	* Titanium
* Hastelloy B	* Tantalum
	* Platinum

table 2

Usable FLANGE, Diameter and Number of bolts with maximum set torque.

DN		PN16			PN25			PN40			ANSI150			ANSI300		
[mm]	["]	Db	Nb	T [Nm]	Db	Nb	T [Nm]	Db	Nb	T [Nm]	Db	Nb	T [Nm]	Db	Nb	T [Nm]
25	1"	M12	4	20	M12	4	24	M12	4	28	1/2"	4	18	5/8"	4	23
40	1" 1/2	M16	4	30	M16	4	35	M16	4	41	1/2"	4	23	3/4"	4	30
50	2"	M16	4	35	M16	4	40	M16	4	47	5/8"	4	33	5/8"	8	23
65	2" 1/2	M16	4	48	M16	8	38	M16	8	38	5/8"	4	47	3/4"	8	30
80	3"	M16	8	35	M16	8	40	M16	8	47	5/8"	4	60	3/4"	8	48
100	4"	M16	8	48	M20	8	98	M20	8	116	5/8"	8	47	3/4"	8	68
125	5"	M16	8	61	M22	8	105	M22	8	125	3/4"	8	67	3/4"	8	90
150	6"	M20	8	85	M22	8	110	M22	8	131	3/4"	8	81	3/4"	12	90
200	8"	M20	12	110	M22	12	125	M27	12	150	3/4"	8	108	7/8"	12	82
250	10"	M22	12	110	M27	12	135	M30	12	250	7/8"	12	95	1"	16	90
300	12"	M22	12	130	M27	16	230	M30	16	300	7/8"	12	108	1" 1/8	16	110

The nuts and bolts are considered new and correctly greased.

table 4

General characteristics of MUT 1000 EL sensors

Available diameters[mm]	25 mm	40 mm	50 mm	65 mm	80 mm	100 mm	125 mm	150 mm	200 mm	250 mm	300 mm
	1"	1.1/2"	2"	2.1/2"	3"	4"	5"	6"	8"	10"	12"
Joints: coupling flanges	UNI2223			ANSI 150				ANSI 300			
Maximum pressure	40 bar for diameters inferior to DN150						16 bar for diameters DN200				
Liquid temperature	Lining: PTFE						-40°C, +180°C [1]				
Degree of protection	IP67/IP68 continuous immersion at a 1,5 m (IEC 529)										
Converters compatibility	MC 106 A		MC 106 B		MC 308		MC 308 C		MC 108		MC 608
Dimensions	See figure 2										
Parts in contact with the liquid	Liner: PTFE / Ebonite										
Electric connections	Cable gland PG 11 + terminal box + sealing resin										

1] Compact version Tmax 80°C.

table 5

Weight of mut 1000 EL sensors in the separate version without package.

DN	[mm]	25	40	50	65	80	100	125	150	200	250	300
DN	["]	1"	1" 1/2	2"	2" 1/2	3"	4"	5"	6"	8"	10"	12"
PESO	[kg]	2,1	2,5	3,0	4,5	6,5	7,5	9,5	11,5	17	21	26

table 6

Fig. 2 - Overall dimensions.

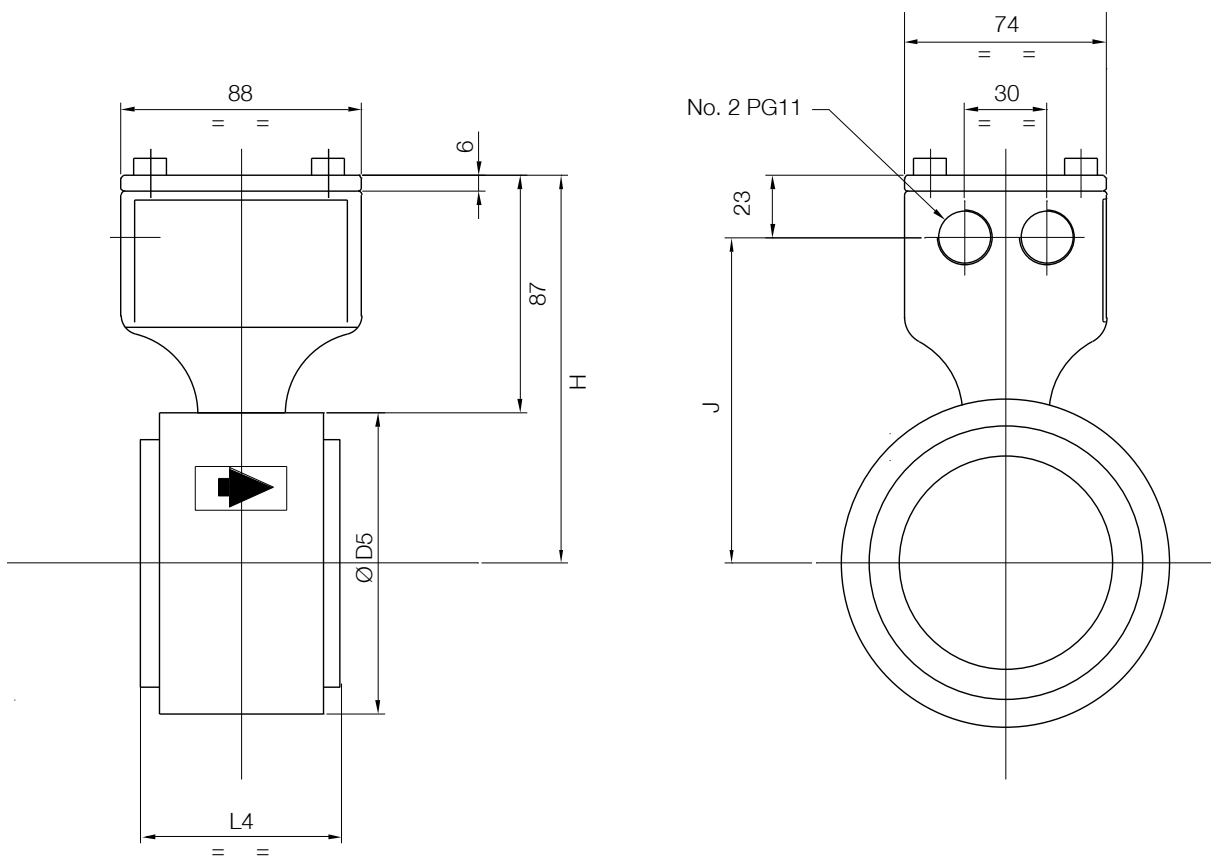

MUT 1000 EL Separate

Ø DN	Ø D5	L4	J	H
[mm]	[mm]	[mm]	[mm]	[mm]
25	64	90 ⁰ ₋₃	96	119
32	77	90 ⁰ ₋₃	102.5	125.5
40	82	90 ⁰ ₋₃	105	128
50	98	90 ⁰ ₋₃	113	136
65	114	95 ⁰ ₋₃	121	144
80	127	95 ⁰ ₋₃	127.5	150.5
100	152	110 ⁰ ₋₃	140	163
125	178	110 ⁰ ₋₃	153	176
150	206	130 ⁰ ₋₃	167	190
200	257	145 ⁰ ₋₃	192.5	215.5
250	311	145 ⁰ ₋₅	219.5	242.5
300	362	150 ⁰ ₋₅	245	268

table 7

Fig. 3 - MUT 1000 EL Compact - Converter MC 106 / 308 ABS Horizontal

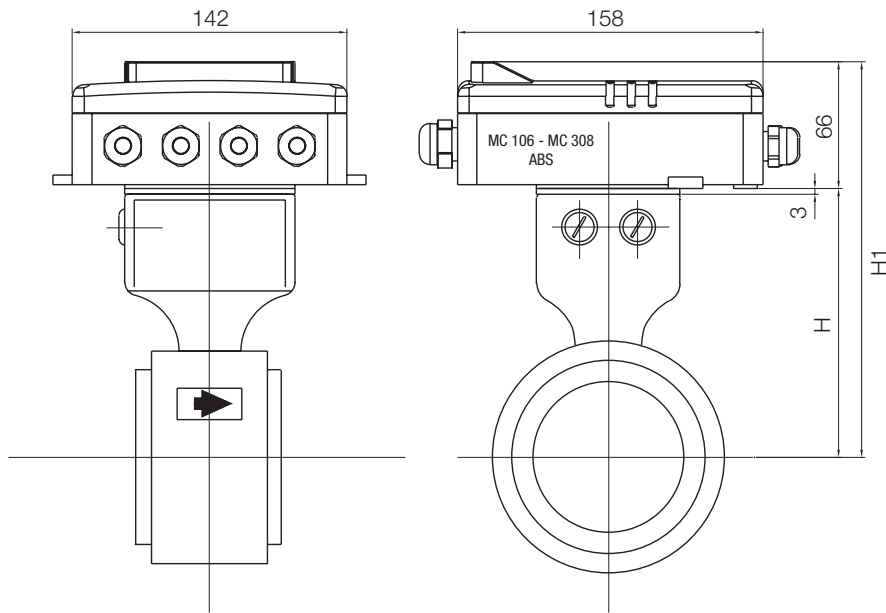

Ø DN	H	H1	L4
[mm]	[mm]	[mm]	[mm]
25	116	182	90 ⁰ ₋₃
32	122.5	168.5	90 ⁰ ₋₃
40	125	191	90 ⁰ ₋₃
50	133	199	90 ⁰ ₋₃
65	141	207	95 ⁰ ₋₃
80	147.5	213.5	92 ⁰ ₋₃
100	160	226	110 ⁰ ₋₃
125	173	239	110 ⁰ ₋₃
150	187	253	125 ⁰ ₋₃
200	212.5	278.5	145 ⁰ ₋₃
250	239.5	305.5	145 ⁰ ₋₅
300	265	331	150 ⁰ ₋₅

table 8

Fig. 4 - MUT 1000 EL Compact - Converter MC 308 ABS Horizontal

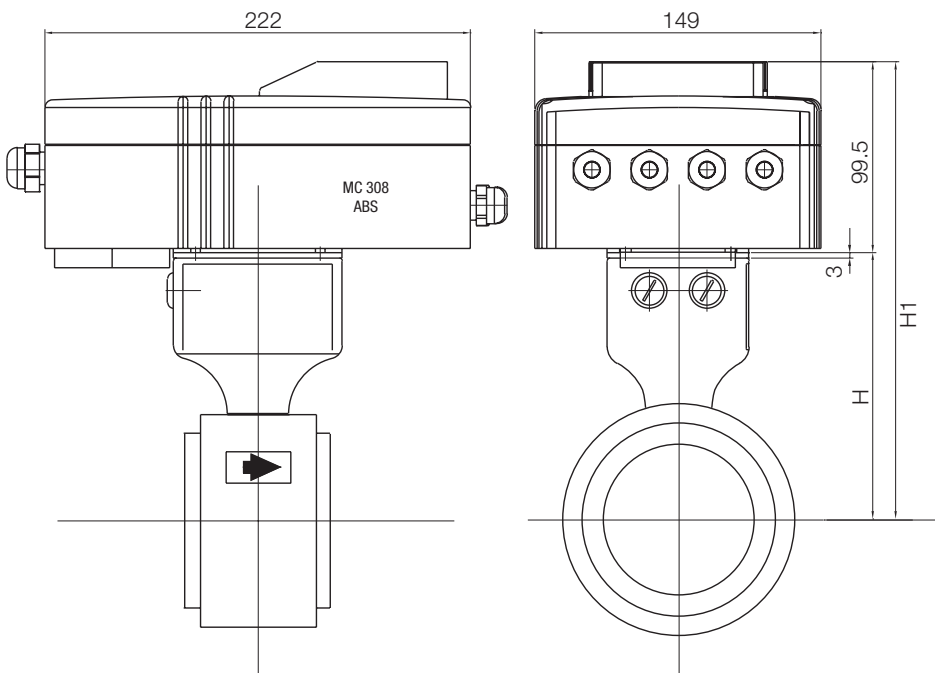

Ø DN	H	H1	L4
[mm]	[mm]	[mm]	[mm]
25	116	215.5	90 ⁰ ₋₃
32	122.5	222	90 ⁰ ₋₃
40	125	224.5	90 ⁰ ₋₃
50	133	232.5	90 ⁰ ₋₃
65	141	240.5	95 ⁰ ₋₃
80	147.5	247	92 ⁰ ₋₃
100	160	259.5	110 ⁰ ₋₃
125	173	272.5	110 ⁰ ₋₃
150	187	286.5	125 ⁰ ₋₃
200	212.5	312	145 ⁰ ₋₃
250	239.5	339	145 ⁰ ₋₅
300	265	364.5	150 ⁰ ₋₅

table 9

Fig. 5 - MUT 1000 EL Compact - Converter MC 308 ABS Vertical

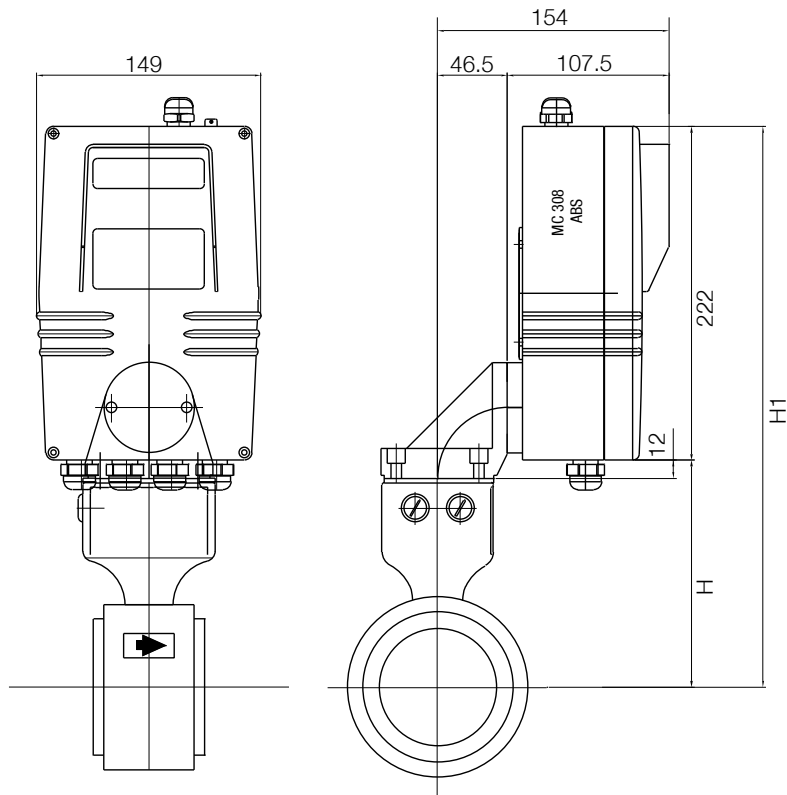

Ø DN	H	H1	L4
[mm]	[mm]	[mm]	[mm]
25	128	350	90 ⁰ ₋₃
32	134.5	356.5	90 ⁰ ₋₃
40	137	359	90 ⁰ ₋₃
50	145	367	90 ⁰ ₋₃
65	153	375	95 ⁰ ₋₃
80	159.5	381.5	92 ⁰ ₋₃
100	172	394	110 ⁰ ₋₃
125	185	407	110 ⁰ ₋₃
150	199	421	125 ⁰ ₋₃
200	224.5	446.5	145 ⁰ ₋₃
250	251.5	473.5	145 ⁰ ₋₅
300	277	499	150 ⁰ ₋₅

table 10

Fig. 6 - MUT 1000 EL Compact - Converter MC 108 / 308 Aluminium Vertical

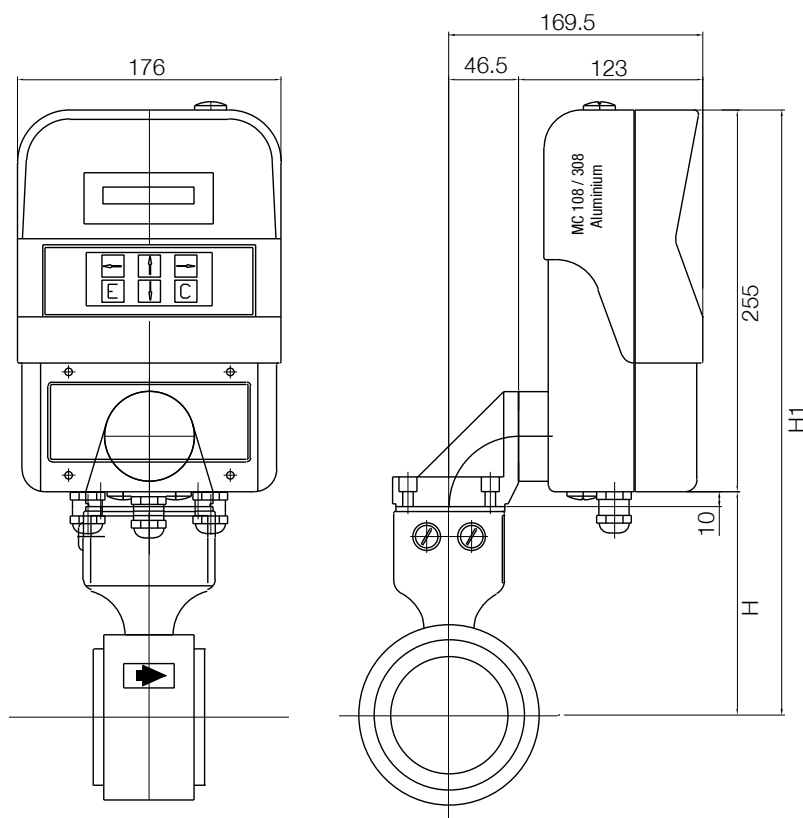

Ø DN	H	H1	L4
[mm]	[mm]	[mm]	[mm]
25	126	381	90 ⁰ ₋₃
32	132.5	387	90 ⁰ ₋₃
40	135	390	90 ⁰ ₋₃
50	143	398	90 ⁰ ₋₃
65	151	406	95 ⁰ ₋₃
80	157.5	412.5	92 ⁰ ₋₃
100	170	425	110 ⁰ ₋₃
125	183	438	110 ⁰ ₋₃
150	197	452	125 ⁰ ₋₃
200	222.5	477.5	145 ⁰ ₋₃
250	249.5	504.5	145 ⁰ ₋₅
300	275	530	150 ⁰ ₋₅

table 11

Fig. 7 - MUT 1000 EL Compact - Converter MC 308 C

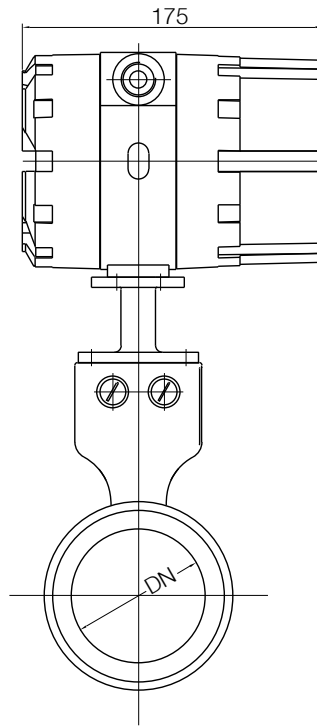
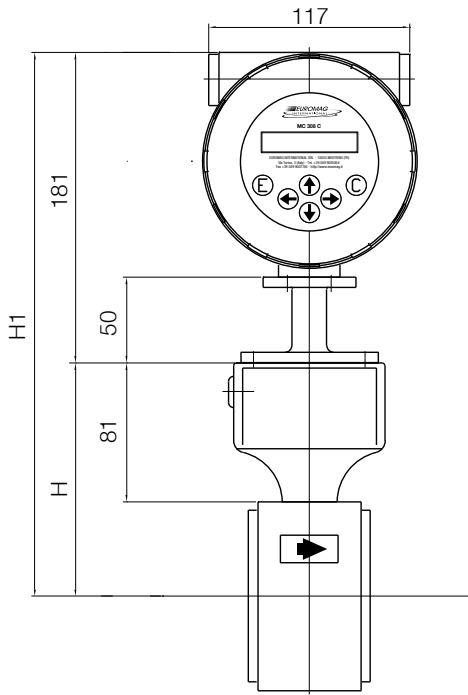

Ø DN	H	H1
[mm]	[mm]	[mm]
25	113	294
32	119.5	300.5
40	122	303
50	130	311
65	138	319
80	144.5	325.5
100	157	338
125	170	351
150	184	365
200	209.5	390.5
250	236.5	417.5
300	262	443

table 12

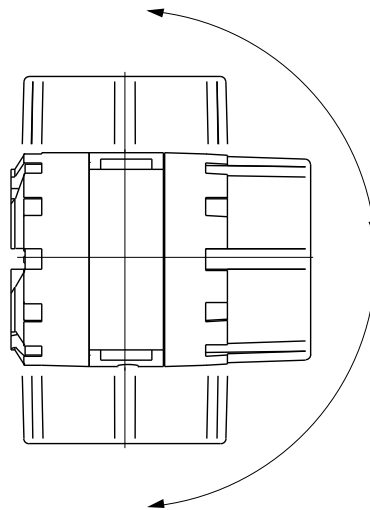

POSSIBLE ROTATION
SUPERIOR VIEW

Fig. 8 - Flowrate expressed in m³/h, according to the liquid velocity, available for all diameters of sensors MUT1000 EL.

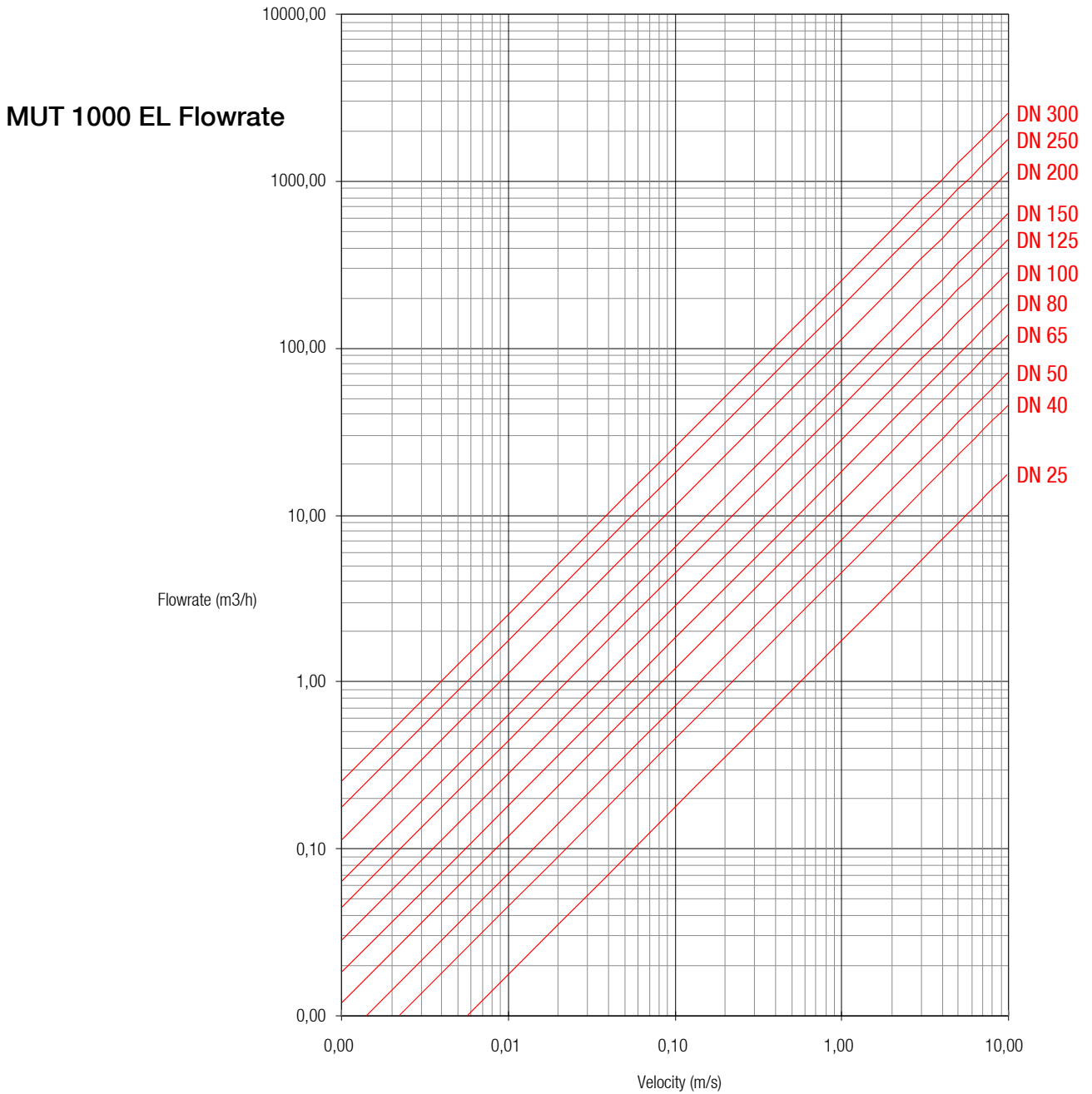

The data shown in this catalogue are subject to modification without prior notice.