

# Bermad Model: 400E 7BM Double Interlock Preaction Electric/Electric Release System

Trim Illustration Vertical Installation

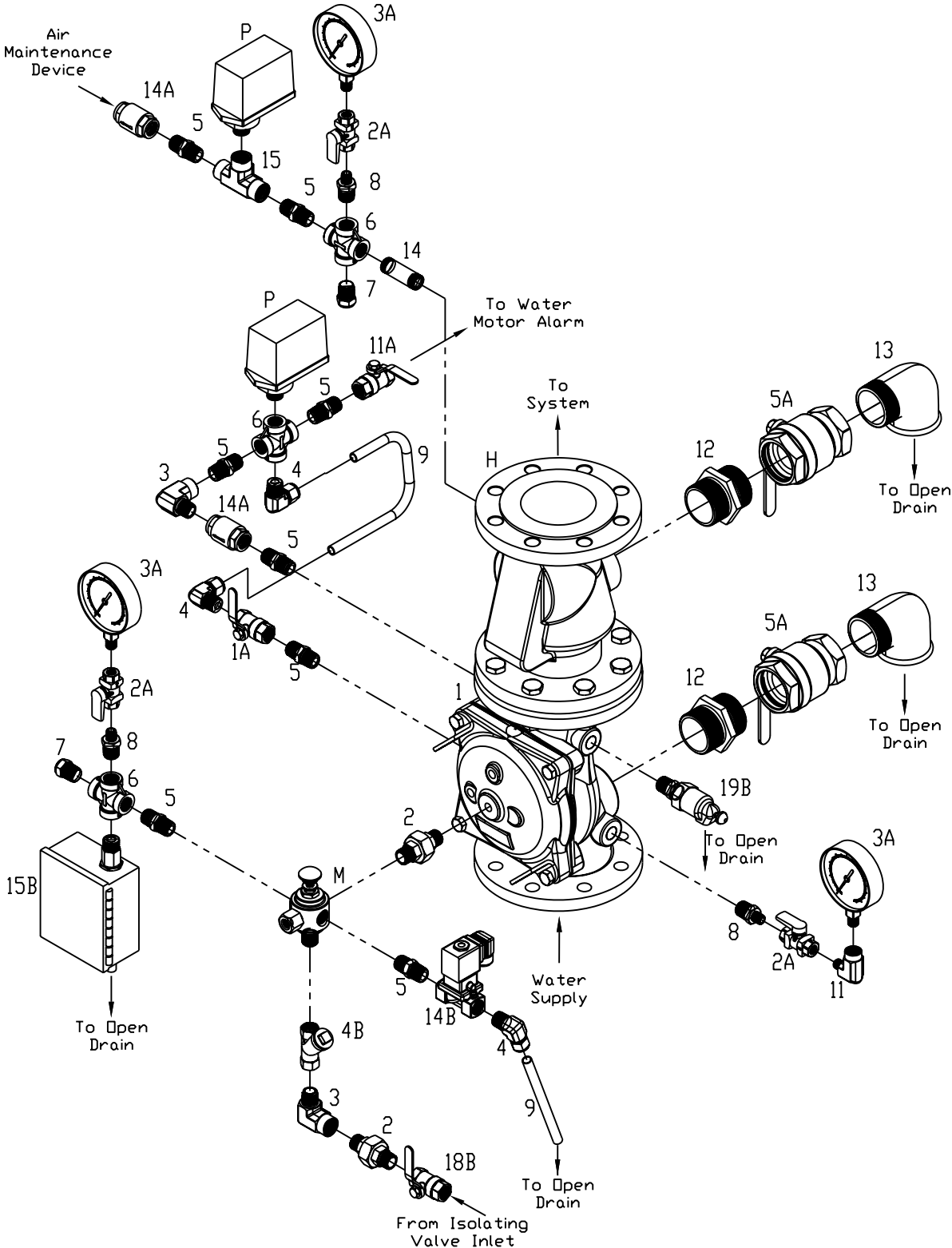

NOTE:  
Valve must be trimmed as shown.  
Any deviation in trim size or arrangement  
may affect the proper operation of the valve.

**Bermad Double Interlock Preaction  
Electric/Electric Release System  
Model: FP-400E-7BM / 700E-7BM  
Trim Component List**

Item	Description	Qty	Note
1	MAIN DELUGE VALVE	1	
2	UNION 1/2"	2	
3	STREET ELBOW 1/2"	2	
4	MALE ELBOW 1/2"X1/2"	3	
5	NIPPLE 1/2"	8	
6	CROSS 1/2"	3	
7	SQUARE PLUG 1/2"	2	
8	REDUCING NIPPLE 1/2"X1/4"	3	
9	TUBE 1/2"	1	
11	STREET ELBOW 1/4"	1	
12	DRAIN NIPPLE 3/4"	2	4
13	DRAIN ELBOW 3/4"	2	4
14	NIPPLE 1/2"X3.5"	1	
15	FEMALE TEE 1/2"	1	
1A	ALARM TEST VALVE 1/2"	1	
2A	GAUGE VALVE 1/4"	3	
3A	PRESSURE GAUGE 4"	3	2
4B	PRIMING STRAINER 1/2"	1	
5A	DRAIN VALVE - 3/4" BALL VALVE	2	1,4
11A	ALARM SHUTOFF VALVE - 1/2" BALL VALVE	1	
14A	CHECK VALVE 1/2"	2	
14B	SOLENOID VALVE 1/2" ASCO 8210G207	1	5
15B	MANUAL EMERGENCY RELEASE MODEL-D	1	1
18B	PRIMING VALVE - 1/2" BALL VALVE	1	
19B	DRIP CHECK	1	5
H	CHECK VALVE SWING TYPE 2" - 10"	1	5
M	MANUAL RESET DEVICE ASSY.	1	5

**Optional System Items:**

P	PRESSURE SWITCH	5	1
W	WATER MOTOR ALARM	5	1

**Notes:**

- (1) Shall be UL Listed in accordance with UL 258
- (2) Shall be UL Listed in accordance with UL 393
- (3) Shall be UL Listed in accordance with UL 753
- (4) For 2" : 3/4" Drain Valve  
For 2 1/2" & 3" : 1 1/2" Drain Valve  
For 4" and larger : 2" Drain Valve
- (5) Shall be UL Listed for fire protection service
- (6) Construction material Brass/S.S 316 or corrosion resistant equivalent