

Maintenance, set up and installation instructions

Air vent for aqueducts - Mod. "FOX - 3 functions" - DN 1"

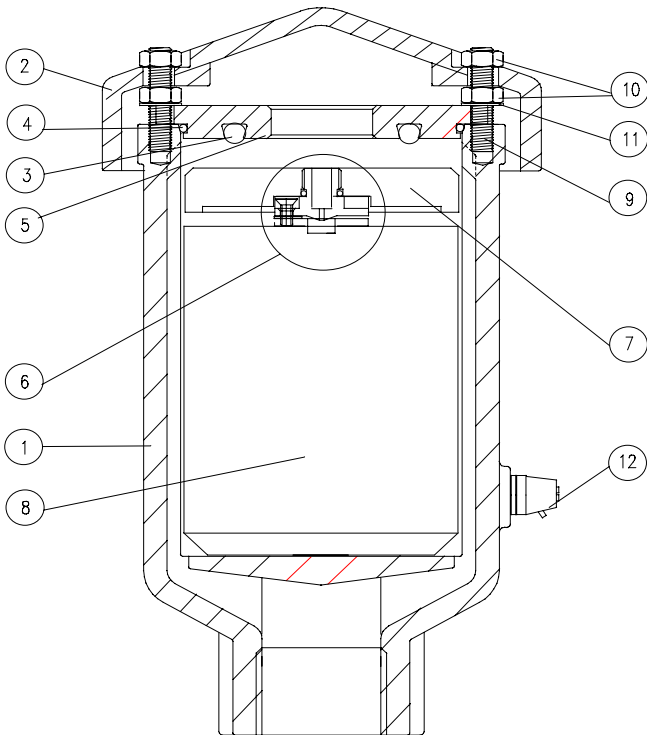

POS.	COMPONENT	MATERIAL
1	Body	GS400-12
2	Cap	GS400-12
3	O-ring	NBR
4	O-ring	NBR
5	Seat	Bronze
6	Nozzle subset	
a	Nozzle	S.S. AISI 316
b	Gasket holder	S.S. AISI 316
c	Gasket	Silicone
d	O-Ring	NBR
e	Screws M3	S.S. AISI 316
f	Washer M3	S.S. AISI 316
7	Upper flat	Polipropilene
8	Float	Polipropilene
9	Studs	S.S. AISI 304
10	Bolts	S.S. AISI 304
11	Washers	S.S. AISI 304
12	Draining cock 1/8	Brass
Mobile block spare parts 3-4-6-7-8		

Installation

Before installing the air valve it is necessary make sure that all the pipes of the system are properly cleaned to avoid that rubbles or debris could damage its internal part. Make sure the pit is large enough and easy to access to carry out inspection procedures, it will be provided with a drain for maintenance. The air valve must be placed in a

vertical position on a Te piece and separated by the main pipe by a gate valve.

The pipe must be filled with a max velocity of 1 m/sec, in particular during the final phase we have to pay attention slowing down the incoming water because its abrupt stop could cause high overpressures likely to damage the entire hydraulic system.

Maintenance

The air valve design is quite simple and sturdy and for that it doesn't need a particular maintenance, we strongly recommend though to check it regularly at least twice per year. All our air valves are equipped with a drainage cock (12) to relief the pressure during maintenance. Operated by a screwdriver, it will indicate us the perfect functioning of the product allowing the exit of water when opened, in case of air coming out there will be some problems that need to be solved. To do so it is mandatory to close the gate valve positioned below, and relief the pressure through the drainage cock. Now proceed operating on the internal components, easy to be replaced from above, as follows:

- Unscrew the nuts (10) on the, pull out the cover (2), unscrew the nuts underneath (10) and pull out the washers (11);
- Extract the sealing seat(5) and make sure that the lateral o-ring (4) and the one on the upper flat (3) are not ruined.
- Open the gate valve just a little bit to let the water enter the air vent pushing up the internal mobile block (6-7-8) to pull it out .
- Loosen the upper flat (7) from the nozzle cleaning it up
- Clean the float (8) and act on the air releasing device as explained below.

To reassemble the air vent simply proceed backwards

How to service the air releasing device "nozzle - gasket holder"

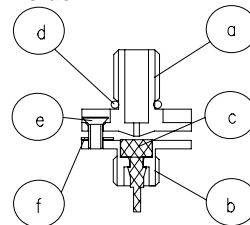

Put the float on a rigid surface and proceed as follows using the picture above :

- Loosen the three M3 (e);
- Pull out and clean the three washers (f) underneath;
- Clean the nozzle (a), if necessary using a strip of sand paper, and check the o-ring (d) washing it as well;
- Check the basket (c) status and clean it, replacing it if necessary. If so unscrew the gasket holder (b), by means of a wrench 24, from the float and extract the basket out of its seal, then replace it making sure the end of it swallowtailed goes through the small orifice and remains tight.

To reassemble it simply follow the instructions below:

- Screw the gasket holder (b), the basket inside of it, inside the float with a drop of LOCTITE 50
- Position the three washers in ss on the basket holder corresponding holes. Now put the nozzle with its o-ring (d) to make its holes match with the gasket holder's ones.
- Screw the three M3 (e) with a little bit of LOCTITE 50 untill they reach the float's surface, and make sure their flat tip don't stretch out of the nozzle when it is squeezed on the gasket holder.

- Try to lift the nozzle manually and make sure it comes up without any friction.
Should you need any spare parts please refer to the legend.

TECHNICAL FEATURES

MAINTENANCE

Period of maintenance

The suggested maintenance schedule is based on typical maintenance which has been carried out by water companies that consider the reliability and operation of their intended function to be important to the transfer system.

The following test procedures are not unique to the CSA products and are only used as a guideline should a water company wish to inspect and test the products operation. The suggested frequency of maintenance and suggested functions are detailed as follows :

Valve Function Test – (Yearly)

The valve function test is a procedure used in order to ensure the three functions of the valve are active. The test involves isolating the valve from the pipeline in order that the kinetic and automatic floats are made to operate under vacuum conditions. This is done by the following procedure.

1. Close the gate valve under the air valve to isolate the line pressure from the valve.
2. Open the drain valve located on the side of the valve (12) with a flat head screw-driver in order that the water drains out of the valve body and the floats drop to their lower position.
3. Close the drain valve and then open the gate valve under the air valve to check the operation of the kinetic and automatic air release function.

Internal inspection of valves – (every 2 years)

Should the water quality of the pipeline have considerably varying water conditions (i.e. high degree of turbidity changes), it may be required to internally check the body of the valve for debris or barnacles that may grow inside the valve.

We suggest that the valve is isolated from the pipeline by the gate valve and the upper mechanism removed. Inspection of the inside of the body and cleaning of any growth that may appear in the walls and on the float mechanism.

Once the components are cleaned, re-assemble into the valve body and test the operation of the valve for valve function. As in “Valve function test”

Inspection of O ring seat– (every 5 years)

We suggest that every 5 years, the valve isolated from the pipeline and the upper sealing O ring (3) inspected for its sealing function. Should there be any signs of compression, the seal should be replaced.

We stress that these tests are only suggestions are ant not unique to the CSA product.

Working conditions

Max temperature : 70°C
Max internal pressure : 40 bar
Minimum internal pressure : 0.5 bar

